

**BALDOR**

**BALDOR® • RELIANCE**

**Part Information Packet**

**CLARK TRANSMISSION CO.**

**IDM3661T**

**3HP, 1760RPM, 3PH, 60HZ, 184TC, 0628M, TEBC, F1**

Part Detail							
Revision:	P	Status:	PRD/A	Change #:		Proprietary:	No
Type:	AC	Prod. Type:	0628M	Elec. Spec:	06WGW356	CD Diagram:	
Enclosure:	TEBC	Mfg Plant:		Mech. Spec:	06F552	Layout:	
Frame:	184TC	Mounting:	F1	Poles:	04	Created Date:	
Base:	RG	Rotation:	R	Insulation:	H	Eff. Date:	06-18-2009
Leads:	9#16	Literature:		Elec. Diagram:		Replaced By:	

**Nameplate NP1162L**

CAT NO	IDM3661T						
SPEC.	06F552W356G1						
FRAME	184TC	HP	3 TE				
VOLTS	230/460						
MAG CUR	4.2/2.1	FLA	8/4				
RPM	1760	RPM MAX	6000				
HZ	60	PH	3	CLASS	H		
SER.F.	1.00	DES	B	SL HZ	1.3		
NEMA-NOM-EFF	89.5	WK2	0.26				
BLWR V	115	PH	1	HZ	60	A	.26
RATING	40C AMB-CONT						
DE BRG	6206	ODE BRG	6205				
SER.NO							

Parts List		
Part Number	Description	Quantity
SA056379	SA 06F552W356G1	1.000 EA
RA050935	RA 06F552W356G1	1.000 EA
HW3201A05	3/8-16 EYEBOLT	1.000 EA
06CB3000	CONDUIT BOX CAST	1.000 EA
06GS1000	GASKET, CONDUIT BOX	1.000 EA
51XW2520A12	.25-20 X .75, TAPTITE II, HEX WSHR SLTD	2.000 EA
11XW1032G06	10-32 X .38, TAPTITE II, HEX WSHR SLTD U	1.000 EA
HW3001B01	BRASS CUP WASHER, FOR #8 SCREW	1.000 EA
36EP1101B41	FR TEBC 205 BRG W/ GRSR & THRU-SHAFT ENC	1.000 EA
HW4500A01	1641B(ALEMITE)400 UNIV, GREASE FITT	1.000 EA
HW5100A05	WVY WSHR F/205 & 304 BRGS	1.000 EA
36EP1300A01SP	PU ENDPLATE, MACH	1.000 EA
HW4500A01	1641B(ALEMITE)400 UNIV, GREASE FITT	1.000 EA
10XN2520A26	1/4-20X 1 5/8 HEX HD	4.000 EA
HW1001A25	LOCKWASHER 1/4, ZINC PLT .493 OD, .255 I	4.000 EA
HA3101A34	THRUBOLT- 1/4-20 X 10.375	4.000 EA
10XN2520A08	1/4-20X1/2 HEX HEAD CAP	1.000 EA
HA3218A05	M/FE STANDOFF UNIC#SX1043.25-20 .38 HEX	3.000 EA
10XN2520A06	1/4 20X3/8 HX HD CAP	3.000 EA
HW1001A25	LOCKWASHER 1/4, ZINC PLT .493 OD, .255 I	3.000 EA
06CB3500	CONDUIT BOX LID - ALUMINUM DIE CAST	1.000 EA
06GS1001	GASKET, CONDUIT BOX LID	1.000 EA
51XW2520A12	.25-20 X .75, TAPTITE II, HEX WSHR SLTD	2.000 EA
HA1005A03SP	SLINGER, OD 1.750, ID .938, 205 BRG	1.000 EA

Parts List (continued)		
Part Number	Description	Quantity
HW2501E16	KEY, 1/4 SQ X 1.750	1.000 EA
HA7000A02	KEY RETAINER RING, 1 1/8 DIA, 1 3/8 DIA	1.000 EA
MJ5004A05	#242-21 LOCTITE GENERAL PURPOSE MED. STR	0.005 EA
85XU0407S04	4X1/4 U DRIVE PIN STAINLESS	2.000 EA
LB1115	LABEL,LIFTING DEVICE	1.000 EA
LB1009	LABEL,ROTATION DIRECTION (ON ROLLS)	1.000 EA
MJ1000A02	GREASE, POLYREX EM EXXON	0.050 LB
06FH5001A02	BLOWER ASSY. 06FH4001, EF0001	1.000 EA
MG1000G27	PAINT- S9282E CHARCOAL GREY	0.028 GA
LC0697	CONN LABEL - 1 PH, SGL VOLT, 2-LEAD	1.000 EA
LB1125C01	STD (STOCK) CARTON LABEL BALDOR WITH FLA	1.000 EA
LC0145B01	CONNECTION LABEL	1.000 EA
LB1119	WARNING LABEL	1.000 EA
NP1162L	INV, SS, UL CSA, W/O THERMAL, LASER	1.000 EA
G0PA1000	PACKAGING GROUP	1.000 EA

CD0005

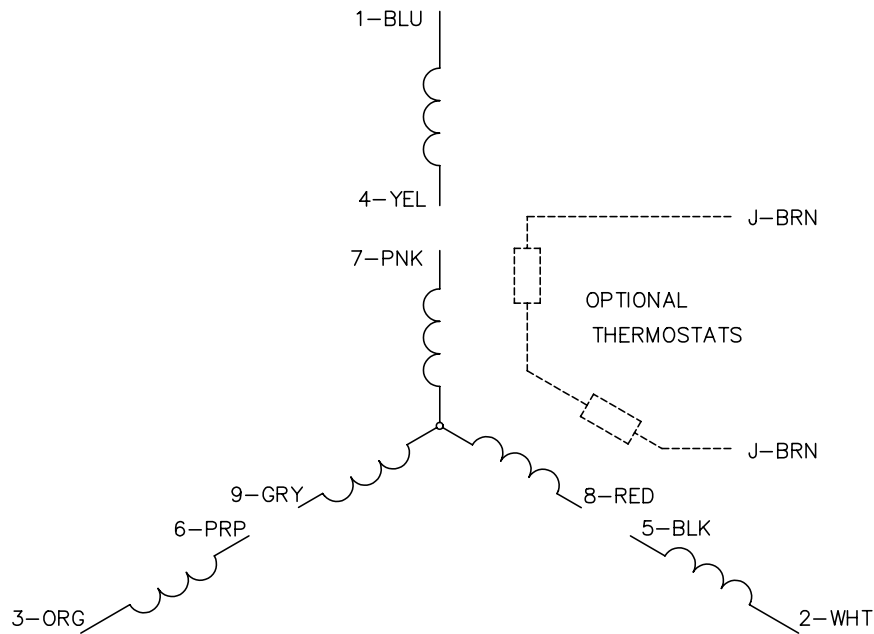

LOW VOLTAGE  
(2Y)

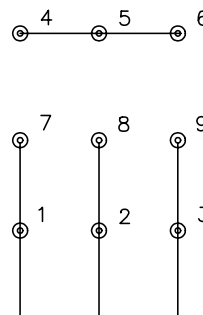

LINE

HIGH VOLTAGE  
(1Y)

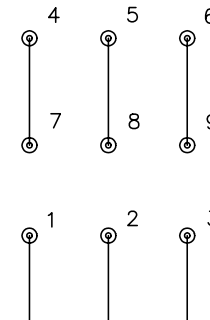

LINE

NOTES:

1. INTERCHANGE ANY TWO LINE LEADS TO REVERSE ROTATION.
2. OPTIONAL THERMOSTATS ARE PROVIDED WHEN SPECIFIED.
3. ACTUAL NUMBER OF INTERNAL PARALLEL CIRCUITS MAY BE A MULTIPLE OF THOSE SHOWN ABOVE.
4. LEAD COLORS ARE OPTIONAL. LEADS MUST ALWAYS BE NUMBERED AS SHOWN.

REV. DESC: REVISE TO SHOW OPTIONAL COLORS			
REV. LTR: E	BY: JLP	REVISED: 01/19/99 10:15	TDR: 0171435
90000		FILE: AAA00005140	MDL: -
		MTL: -	

**BALDOR ELECTRIC Co.**

3PH, DV, 9 LEADS

CD0005

06LYF552

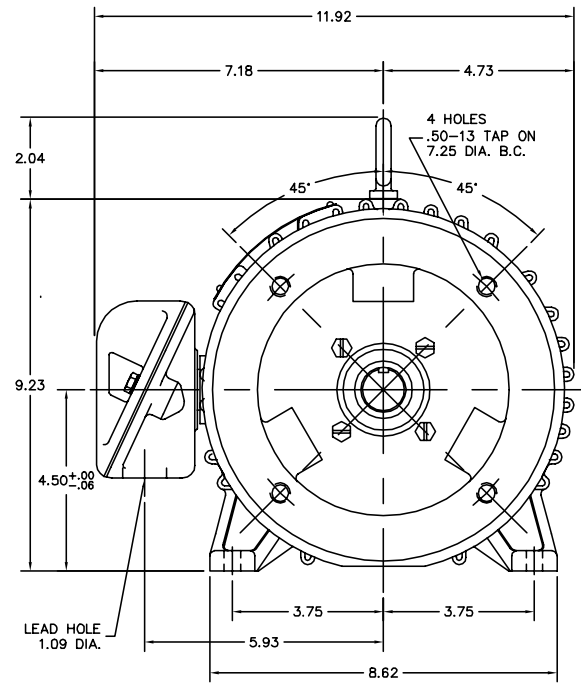
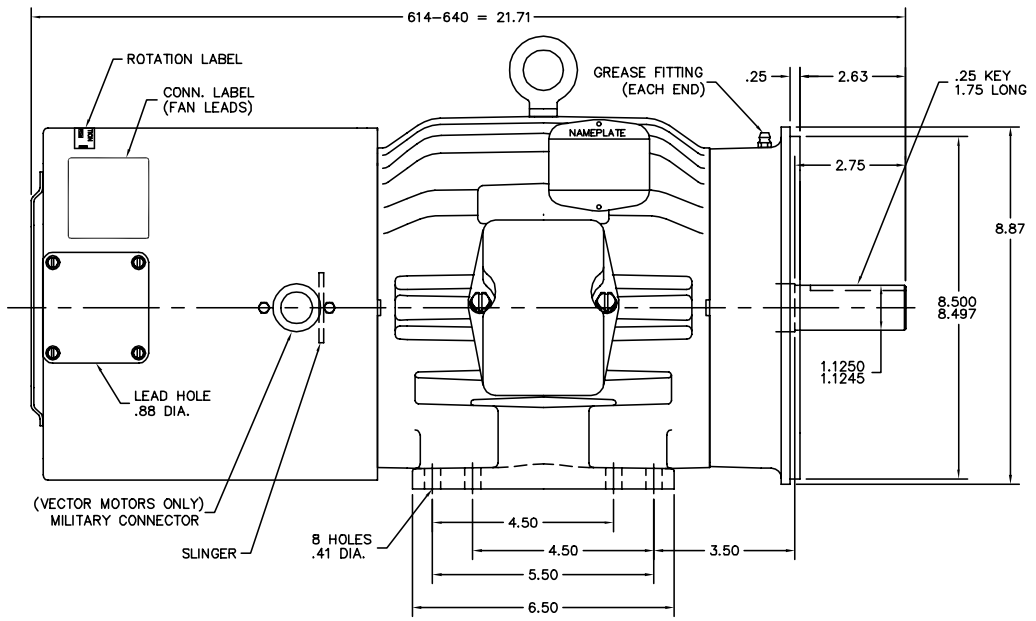

CUSTOMER IS RESPONSIBLE FOR DETERMINING THAT MOTOR PERFORMANCE IS SUITABLE IN THE APPLICATION.

REV. DESC: CORRECT ROTATION LABEL GRAPHICS & LEADER			
REV. LTR: B	BY: DLS	REVISED: 13:53:11 01/10/2002	TDR: 251223
FILE: AAA00070966		REF: 06LYF552	
MTL: -			

<b>BALDOR ELECTRIC Co.</b>
STD HORZ 182-4TC TEBC INVERTER/VECTOR (THRU-SHAFT ENCODER)

06LYF552