

SHIMPO

CIRCULUTE 3000[®]

The ideal reducer for both induction
and servo motor applications



**NEW! Optional Mounting Base
Matches Industry-Standard
Dimensions... See Inside**

Nidec
SHIMPO

Contents

Features & Benefits2-3
 Operating Principles 4
 Model Examples..... 5
 Selection Procedures.....6-7
 Load Classification Table 8
 Model Number Chart 9
 Rating Tables 10-16
 Internal Inertia, Torsional Stiffness, & Standard Lubrication 17

Dimensions-Single Reduction

Base Mount 18-19
 Flange Mount20-21
 Ring Mount22-23

Dimensions-Double Reduction

Double Reduction Tables.....24-25

Shovel Base & Top Mount

Adaptor 26

C-Face Adaptor 26

Reducers for Overhead Conveyor

Applications..... 27

Overhung Load & Miscellaneous

.....28-31

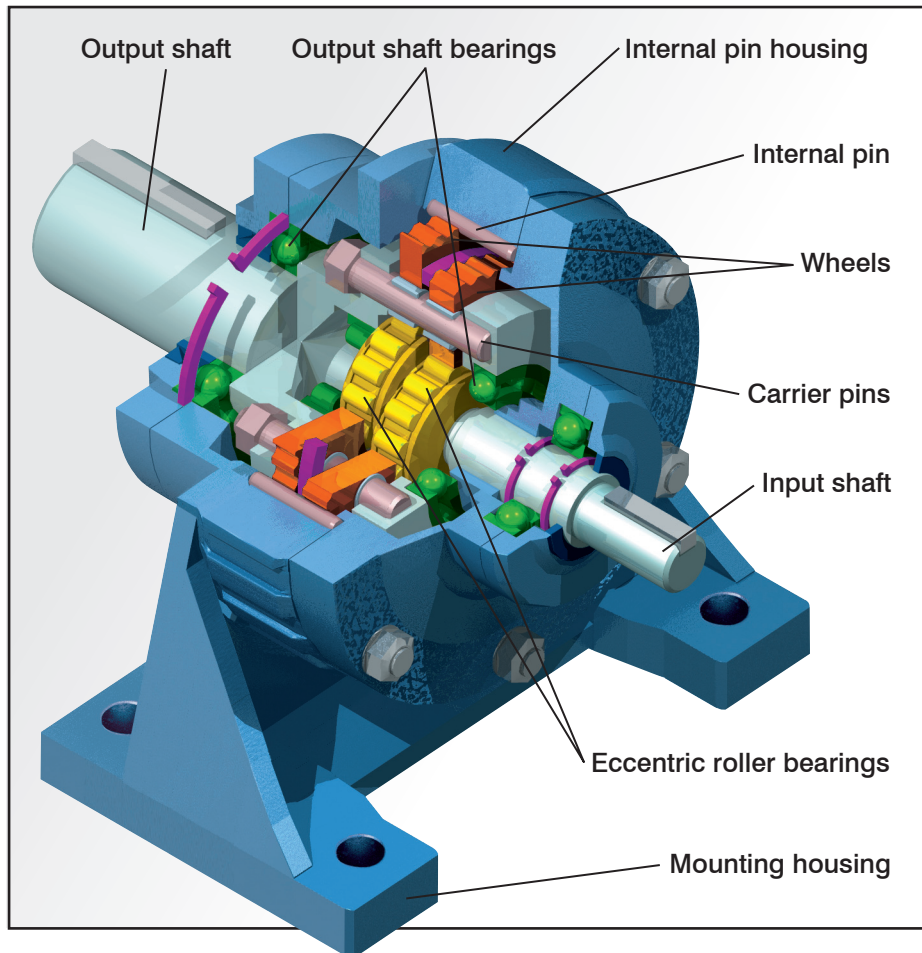

Great Features, Precision Backlash!

The **CIRCULUTE 3000®** Speed Reducer delivers the features today's industry needs. High reduction ratios, without sacrificing efficiency. Compact designs, without requiring special motors. Exceptional shock load capacity, without having to oversize. Greater overhung load capacities, without using expensive special components. A precision backlash option, without resorting to special gearing. All of this, while requiring minimal maintenance.

Optional Mounting Dimensions

CIRCULUTE 3000® is available with mounting and output shaft dimensions equivalent to those of the SM Cyclo® product. Your Shimpo reducer can be dropped in to replace the other brand with no modifications to your mounting plate! This dimensional change is only available on base-mounted units. When ordering, specify the "DI" option.

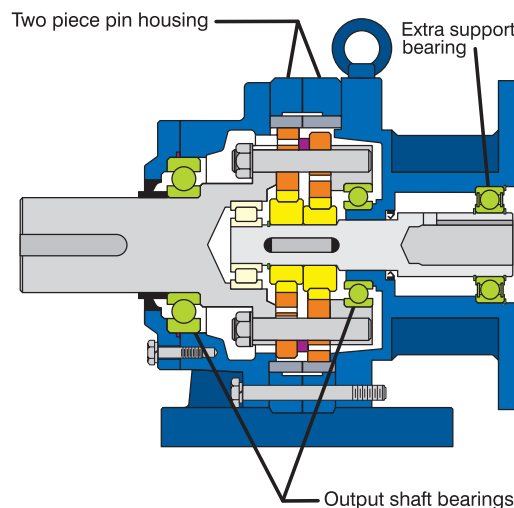

Cross sectional view of a precision backlash **CIRCULUTE 3000®** Reducer. The two piece pin housing provides the ability to preload one wheel against the other, reducing the output shaft backlash to less than 6 arc-min. The extra support bearing prevents fretting corrosion between the quill input shaft and the motor shaft. The long output shaft bearing span provides exceptional overhung load capabilities.

Features & Benefits

Design Features

Operational Benefits

<p>High Efficiency Cycloidal Reducer Design</p>	<ul style="list-style-type: none"> • Single stage reduction ratios up to 71:1 saves space • Rolling motion minimizes friction and wear, reducing heat, resulting in a 95% efficiency rating per stage • 500% shock load capability as there are only compressive forces rather than shear forces on the tooth • Low speed of cycloidal wheel results in minimal reflected inertia, less wear, and extremely long service life • Due to the large overall “tooth / pin” contact area, select a CIRCULUTE³⁰⁰⁰ Reducer using smaller mechanical service factors
<p>Two Backlash Ratings</p>	<ul style="list-style-type: none"> • Standard backlash offers the highest available torque rating at an economical price • Precision backlash results in tighter positional tolerances
<p>Multiple Inputs: NEMA C-Face, Servo Square Flange, Shaft Input, Shovel Base, Top Mount</p>	<ul style="list-style-type: none"> • Versatility to fit whatever prime mover is needed for the application • NEMA and servo input flanges are compact “quill-style” hollow-bore configuration, eliminating input couplings and guards • Quill-style input features an input support bearing to control fretting corrosion between motor shaft and reducer hub, and permit tighter internal tolerances • NEMA input flange includes threaded back-off holes for easy motor removal
<p>Straddle Mount Output Shaft Bearings (sizes D, E, F)</p>	<ul style="list-style-type: none"> • Supports output shaft and drive pins to provide exceptional overhung and thrust load capability, without the need for special bearings or housings
<p>Multiple Mounting Options: Base, Flange, Ring</p>	<ul style="list-style-type: none"> • Versatility to fit anywhere on your machine • Ring style allows output bearing to extend well within the machine for greatest overhung load rating

Mounting Options



Base Mount

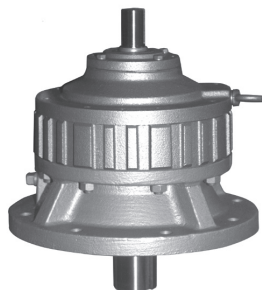

Flange Mount



Ring Mount

Operating Principles

1. When the input shaft makes one rotation, the eccentric roller bearing also rotates once in the same direction.
2. The **CIRCULUTE 3000®** wheel is driven by the eccentric roller bearing. It revolves around the internal pins with its teeth engaging with consecutive pins.
3. When the eccentric roller bearing has completed one full rotation, a **CIRCULUTE 3000®** tooth initially in mesh with a pin will be positioned as many teeth behind its initial position as the difference between the number of internal pins and the number of **CIRCULUTE 3000®** teeth. As a result, the **CIRCULUTE 3000®** wheel rotates slowly in the opposite direction of the input shaft.
4. The rotational motion of the **CIRCULUTE 3000®** wheel is transmitted to the output shaft through the carrier pins.

The reduction ratio of the **CIRCULUTE 3000®** Speed Reducer can be calculated using the following formula:

$$R = \frac{N - M}{M}$$

R = the reduction ratio
N = the number of internal pins
M = the number of **CIRCULUTE 3000®** teeth

Example: N=18 and M=17,

$$R = \frac{18 - 17}{17} = \frac{1}{17} = 17:1$$

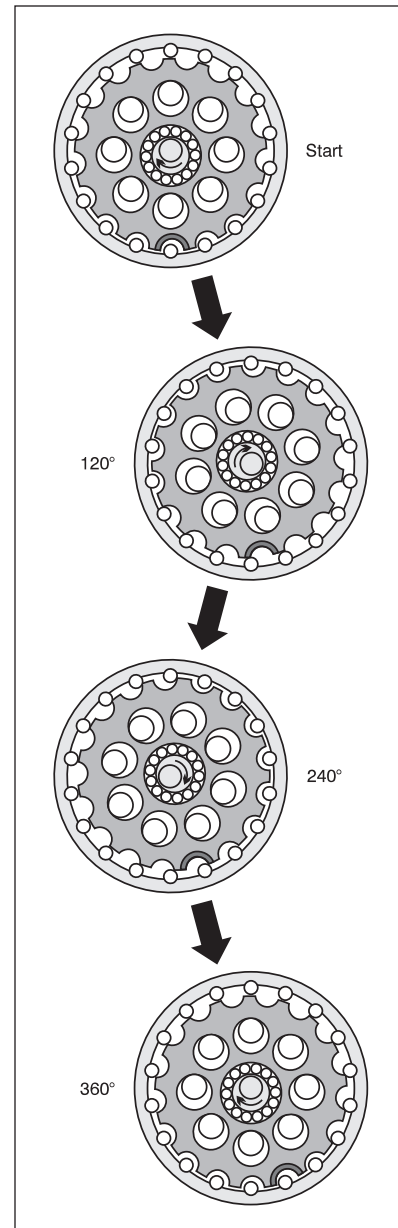
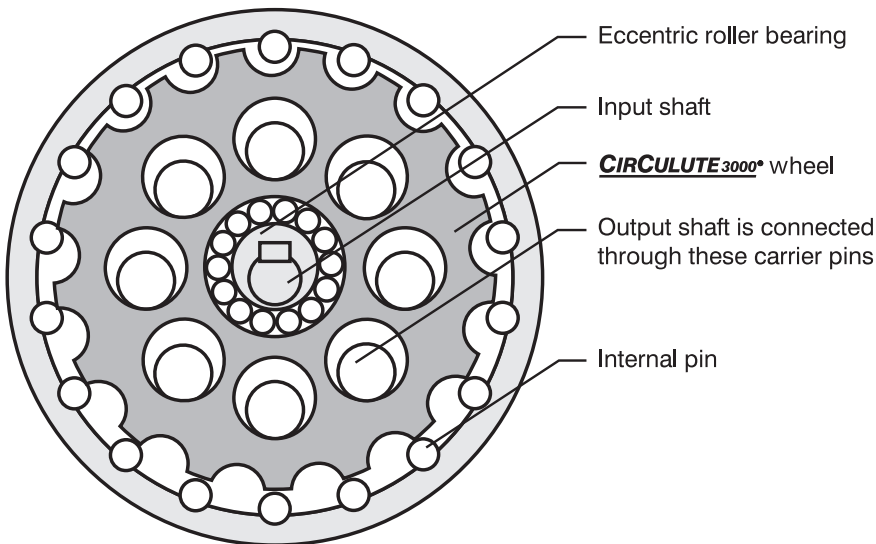





The power train sets **CIRCULUTE 3000®** apart from other speed reducers.

Its main power transmission components include: an eccentric roller bearing drives a wheel around a set of internal pins, keeping rotational inertia low.

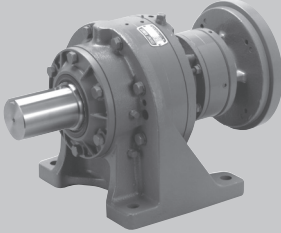
The result: exceptional efficiency, long service life, and reduced wear.

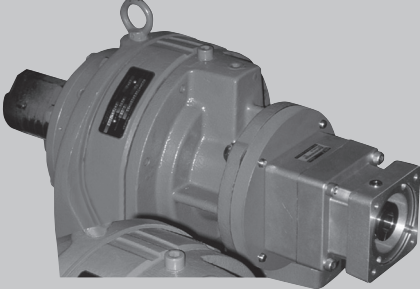
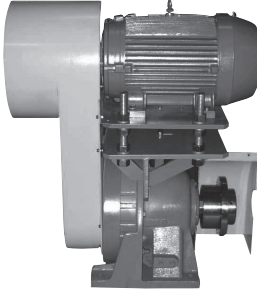
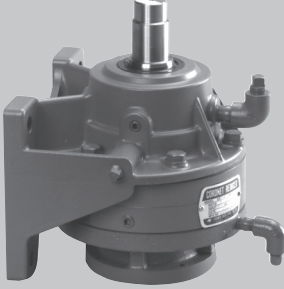
Model Examples

	<p>Double reduction base mount servo input precision backlash – ratio can be from 121:1 to 5,041:1.</p>
	<p>Single reduction flange mount precision backlash – unit can be mounted horizontally or vertically.</p>
	<p>Combination base mount Circulute with Able planetary gearhead as first stage – ratio can be from 33:1 to 5,751:1.</p>
	<p>Single reduction base mount standard backlash with top mount motor adaptor, fully assembled with input fluid coupling, belt drive, output coupling, motor, and OSHA guards.</p>
	<p>Single reduction wall mount precision backlash with special output shaft – unit is oriented for output shaft vertical up.</p>
	<p>Double reduction ring mount standard backlash with grease lubrication – unit is configured with an input shaft for coupling or belt drive connection to the motor.</p>

Selection Procedure for Induction Motor Applications

1. Determine the load classification from the Load Classification Table on page 8.
2. Select the **CIRCULUTE3000®** Reducer service factor from the Service Factor Table (below) for the application taking into consideration the load classification, duration of service, and type of prime mover.
3. Calculate the required reduction ratio by dividing the input shaft rpm by the required output shaft rpm.
4. If selecting the reducer by HP, determine the design HP by multiplying the motor HP by the service factor. If selecting the reducer by torque, determine the design torque by multiplying the required load torque by the service factor.
5. Select the **CIRCULUTE3000®** Reducer frame size from the selection tables on pages 10 - 13, making sure that the catalog rating exceeds either the design HP and/or design torque.
6. Select the required input type from page 9.
7. Select the required mounting type from page 9.
8. Select the required mounting position from page 9.
9. Check the overhung and/or thrust loads on shafts if connected to the load by either a sprocket, sheave, pulley, or gear (pages 28 - 29).
10. Configure the model number (page 9), noting any unusual operating or ambient conditions. Contact SHIMPO Drives Customer Service for questionable items, or applications assistance.

Service Factor Table

Prime Mover	Duration of Service	Load Classification					
		Uniform (U)		Moderate Shock (M)		Heavy Shock (H)	
		AGMA	Circulute	AGMA	Circulute	AGMA	Circulute
Electric Motor	Occasional: 1/2 hour per day	0.50	0.50	0.80	0.80	1.25	1.20
	Intermittent: 3 hours per day	0.80	0.80	1.00	1.00	1.50	1.35
	Up to 10 hours per day	1.00	1.00	1.25	1.20	1.75	1.50
	24 hours per day	1.25	1.20	1.50	1.35	2.00	1.60
Multi-Cylinder Internal Combustion Engine	Occasional: 1/2 hour per day	0.80	0.80	1.00	1.00	1.50	1.35
	Intermittent: 3 hours per day	1.00	1.00	1.25	1.20	1.75	1.50
	Up to 10 hours per day	1.25	1.20	1.50	1.35	2.00	1.60
	24 hours per day	1.50	1.35	1.75	1.50	2.25	1.70
Single Cylinder Internal Combustion Engine	Occasional: 1/2 hour per day	1.00	1.00	1.25	1.20	1.75	1.50
	Intermittent: 3 hours per day	1.25	1.20	1.50	1.35	2.00	1.60
	Up to 10 hours per day	1.50	1.35	1.75	1.50	2.25	1.70
	24 hours per day	1.75	1.50	2.00	1.60	2.50	1.80

Note: AGMA service factors shown are the American Gear Manufacturers' recommendations for conventional gear reducers.

Selection Procedure for Servo Motor Applications

1. Determine the load classification from the Load Classification Table on page 8.
2. Select the **CIRCULUTE 3000**[®] Reducer service factor from the Service Factor Table (below) for the application taking into consideration the load classification and duration of service.
3. Calculate the required reduction ratio by dividing the rated servo motor speed (rpm) by the required output shaft rpm.
4. Multiply the servo motor capacity (kW or HP) by the service factor and select the **CIRCULUTE 3000**[®] Reducer from the selection table based on servo motor rated speed and backlash required (pages 14 - 16) with a rating that exceeds this calculation. This is the tentative selection.
5. Calculate the average torque by using the formula below, making sure that average torque is less than the nominal torque value of the selected **CIRCULUTE 3000**[®] Reducer (T1) as shown in our rating tables.
6. Multiply the selected **CIRCULUTE 3000**[®] Reducer nominal torque value (T1) as shown in our rating tables by 1.5. Make sure that this value exceeds the acceleration torque of the application.
7. Select the required mounting type from page 9.
8. Select the required mounting position from page 9.
9. Check the overhung and/or thrust loads on the output shaft if connected to the load by either a sprocket, sheave, pulley, or gear (pages 28 - 29).
10. Configure the model number (page 9), noting backlash and any unusual operating or ambient conditions. Contact SHIMPO Drives Customer Service for questionable items, or applications assistance.

Service Factor Table

Duration of Service	Load Classification		
	Uniform (U)	Moderate Shock (M)	Heavy Shock (H)
Up to 10 hours per day	1.00	1.20	1.40
24 hours per day	1.20	1.40	1.60

Formula

Where	T _{ave} : Average torque
	T _a : Acceleration torque
	T _r : Running torque
	T _d : Deceleration torque
	t _a : Acceleration time
	t _r : Running time
	t _d : Deceleration time

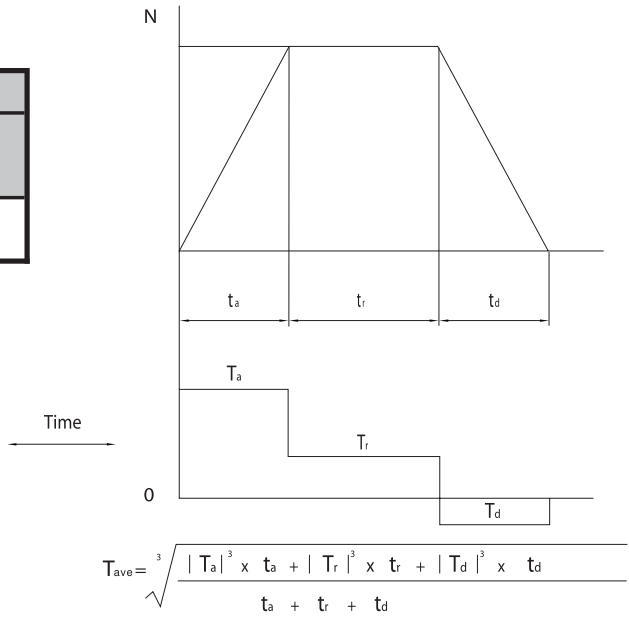

Load Classification Table

U - Uniform Load **M** - Moderate Load **H** - Heavy Shock Load

AGITATORS

Pure Liquids	U
Liquids and Solids	M
Liquids - Variable Density	M
Semi-liquids Variable Density	M*

BLOWER

Centrifugal	U
Lobe	M
Vane	U

BREWING and DISTILLING

Bottling Machinery	U
Brew Kettles - Continuous Duty	U
Cookers - Continuous Duty	U
Mash Tubs - Continuous Duty	U
Scale Hopper Frequent Starts	M

CAN FILLING MACHINES

	U
--	---

CANE KNIVES

	M
--	---

CAR DUMPERS

	H
--	---

CAR PULLERS - Intermittent Duty

	U
--	---

CLARIFIERS

	U
--	---

CLASSIFIERS

	M
--	---

CLAY WORKING MACHINERY

Brick Press	H
Briquette Machine	H
Clay Working Machinery	M
Pug Mill	M

COMPRESSORS

Centrifugal	
Lobe	
Reciprocating	
Multi-Cylinder	M*
Single Cylinder	H*

CONVEYORS - UNIFORMLY LOADED OR FED

Apron	M
Assembly	M
Belt	M
Bucket	M
Chain	U
Flight	U
Oven	U

CONVEYORS - HEAVY DUTY NOT UNIFORMLY FED

Apron	M
Assembly	M
Belt	M
Bucket	M
Chain	M
Flight	M
Live Roll (Package)	M
Oven	M
Reciprocating	H
Screw	M
Shaker	H

CRANES and HOISTS

Main Hoists	
Heavy Duty	H
Medium Duty	M
Reversing	M
Skip Hoists	M
Trolley Drive	M*
Bridge Drive	M*

CRUSHERS

Ore	H
Stone	H

DREDGES

Cable Reels	M
Conveyors	M
Cutter Head Drives	H
Jig Drives	H
Maneuvering Winches	M
Pumps	M
Screen Drive	H
Stackers	M
Utility Winches	M

ELEVATORS

Bucket - Uniform load	U
Bucket - Heavy load	M
Bucket - Continuous	U
Centrifugal Discharge	U
Escalators	U
Freight	M
Gravity Discharge	U
Man Lifts	**
Passenger	**
Service - Hand Lift	H

FANS

Centrifugal	M
Cooling Towers	**
Induced Draft	M
Forced Draft	**
Induced Draft	M
Large (Mine, etc.)	M*
Large Industrial	M*
Light (Small Diameter)	U

FEEDERS

Apron	M
Belt	M
Disc	U
Reciprocating	H
Screw	M

FOOD INDUSTRY

Beet Slicer	M
Cereal Cooker	U
Dough Mixer	M
Meat Grinders	M

GENERATORS - (Not Welding)

	U
--	---

HAMMER MILLS

	H
--	---

LAUNDRY WASHERS

Reversing	M
-----------	---

LAUNDRY TUMBLERS

	M
--	---

LINE SHAFTS

Heavy Shock Load	H
Moderate Shock Load	M
Uniform Load	U

LUMBER INDUSTRY

Barker - Hydraulic - Mechanical	M
Burner Conveyor	M
Chain Saw and Drag Saw	H
Chain Transfer	H
Craneway Transfer	H
De-Barking Drum	H
Edger Feed	M
Gang Feed	M
Green Chain	M
Live Rolls	H
Log Deck	H
Log Haul - Incline	H
Log Haul - Well Type	H
Log Turning Device	H
Main Log Conveyor	H
Off Bearing Rolls	M
Planer Feed Chains	M
Planer Floor Chains	M
Planer Tilting Hoist	M
Re-saw Merry-Go-Round	
Conveyor	M
Roll Cases	H
Slab Conveyor	H
Small Waste Conveyor - Belt	U
Small Waste Conveyor - Chain	M
Log Turning Device	H
Sorting Table	M
Tipple Hoist Conveyor	M
Tipple Hoist Drive	M
Transfer Conveyor	H
Transfer Rolls	H
Tray Drive	M
Trimmer Feed	M
Waste Conveyor	M

MACHINE TOOLS

Bending Roll	M
Notching Press - Belt Driven	*
Plate Planer	H
Punch Press - Gear Driven	H
Tapping Machines	H
Other Machine Tools	
Main Drives	M
Auxiliary Drives	U

METAL MILLS

Draw Bench - Carriage	H
Draw Bench - Main Drive	M
Forming Machines	H
Pinch Dryer & Scrubber Rolls,	
Reversing	*
Slitters	M*
Table Conveyors	
Non-reversing	M
Reversing	H
Wire Drawing & Flattening	
Machine	M
Wire Winding Machine	M

MILLS, ROTARY TYPE

Ball	H
Cement Kilns	**
Dryers & Coolers	M
Kilns	M
Pebble	H
Rod	H
Tumbling Barrels	H

MIXERS

Concrete Mixers, Continuous	M
Concrete Mixers, Intermittent	U
Constant Density	U
Variable Density	M

OIL INDUSTRY

Chillers	M
Oil Well Pumping	**
Paraffin Filter Press	M
Rotary Kilns	M

PAPER MILLS

Agitators (Mixers)	M
Barker Auxiliaries, Hydraulic	M
Barker, Mechanical	M
Barking Drum	H
Beater & Pulper	M
Bleacher U	U
Calendars	M
Calendars - Super	H
Converting Machines,	
except Cutters, Platers	M
Conveyors	U
Couch	M
Cutters, Platers	H
Cylinders	M
Dryers	M
Felt Stretcher	M
Felt Whipper	H
Jordans	H
Log Haul	H
Presses	U
Pulp Machines	M
Reel	M
Stock Chests	M
Suction Roll	U
Washers & Thickeners	M
Winders	U

PRINTING PRESSES U

PULLERS

Barge Haul	M
------------	---

PUMPS

Centrifugal	H
Proportioning	M*
Reciprocating	
Single Acting	
3 or more Cylinders	M
Double Acting	
2 or more Cylinders	*
Single Acting 1 or 2 Cylinders	*
Double Acting	*
Single Cylinder	*
Rotary - Gear Type	H
Rotary - Lobe, Vane	H

RUBBER INDUSTRY

Mixer	H
Rubber Calendar	M
Rubber Mill (2 or more)	M*
Sheeter	M*
Tire Building Machines	**
Tire & Tube Press Openers	**
Tubers & Strainers	M

SEWAGE DISPOSAL EQUIPMENT

Bar Screens	H
Chemical Feeders	H
Collectors, Circuline or	
Straight Line	H
Dewatering Screens	M
Grit Collectors	H
Scum Breakers	M
Slow or Rapid Mixers	M
Sludge Collectors	U
Thickeners	M
Vacuum Filters	M

SCREENS

Air Washing	U
Rotary - Stone or Gravel	M
Traveling Water Intake	U

SLABPUSHERS

	M
--	---

STEERING GEAR

	M
--	---

STOKERS

	U
--	---

TEXTILE INDUSTRY

Batchers	M
Calendars	M
Card Machines	M*
Cloth Finishing Machines,	
(washers, pads, tenters, dryers,	
calendars, etc.)	M
Dry Cans	M
Dryers	M
Dyeing Machinery	M
Knitting Machines (looms, etc.)	*
Looms	M
Mangles	M
Nappers	M
Pads	M
Range Drives	*
Slashers	M
Soapers	M
Spinners	M
Tenter Frames	M
Washers	M
Winders (Other than Batchers)	M
Yarn Preparatory Machines (Cards,	
Spinners, Slashers, etc.)	M

WINDLASS

	M*
--	----

* In view of varying load conditions, it is suggested that these applications be carefully reviewed before a final selection is made.

**Check safety codes and refer to SHIMPO Drives Customer Service.

Model Number Chart for Induction Motor Reducers

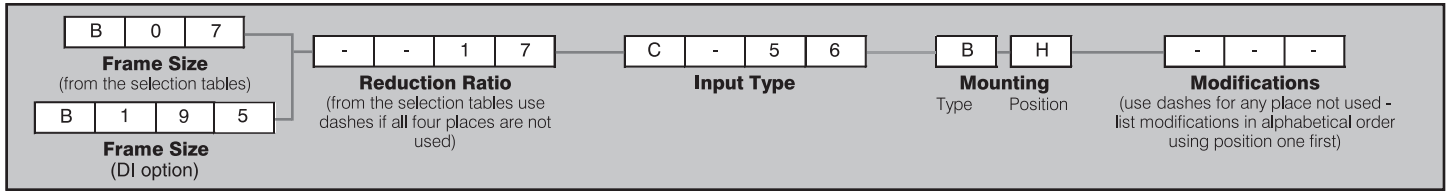

INPUT TYPE

Input Shaft SHFT

Standard Quill Style NEMA C-Face Input

Motor Size	Ordering Code
56C	C-56
143/145TC	C140
182/184TC	C180
213/215TC	C210
254/256TC	C250
284/286TC	C280
324/326TC	C320

For coupling style C-Face adapters, please change "C" to "A" in the ordering code

Shovel Base Input

Motor Size	Ordering Code
56	S-56
143/145T	S140
182/184T	S180
213/215T	S210
254/256T	S250
284/286T	S280
324/326T	S320

For top mount adapters, please change "S" to "T" in the ordering code

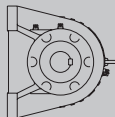
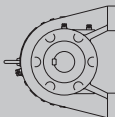
MOUNTING TYPE	MOUNTING POSITION	Position L (Viewed from output shaft)	Position R (Viewed from output shaft)
Mounting Type Ordering Code	Mounting Position Ordering Code		
Base (foot) B	Horizontal H		
Flange F	Vertical Output Shaft Down D		
Ring R	Vertical Output Shaft Up U		
	Ceiling (base mount) C		
	Wall Feet Left (base mount) L		
	Wall Feet Right (base mount) R		

Modifications

Expansion chamber breather (oil filled units).....	E
USDA approved food grade lubricant	F
Oil level gauge	G
High temperature lubricant and acrylic oil seals (104°F to 140°F ambient temperatures)	H
Oil lubrication in place of standard grease lubrication	J
Grease lubrication in place of standard oil lubrication	K
Low temperature lubricant (-4°F to 32°F ambient temperatures)	L
Synthetic lubricant	S
Taper pins (for extreme reversing load applications)	T
Washdown breather (oil filled units)	U
Washdown modifications (a stainless steel sleeve under the output shaft seal, a V-ring deflector on the output shaft, a sealed motor shaft bearing for vertical output shaft down units, and a washdown breather for oil filled units. This modification reduces the usable shaft length	W
White epoxy paint	X
Washdown modifications with white epoxy paint	Y
Steel-It [®] paint	B
Washdown modifications with Steel-It [®] paint	C
Precision backlash	P

Model Number Chart for Servo Motor Reducers

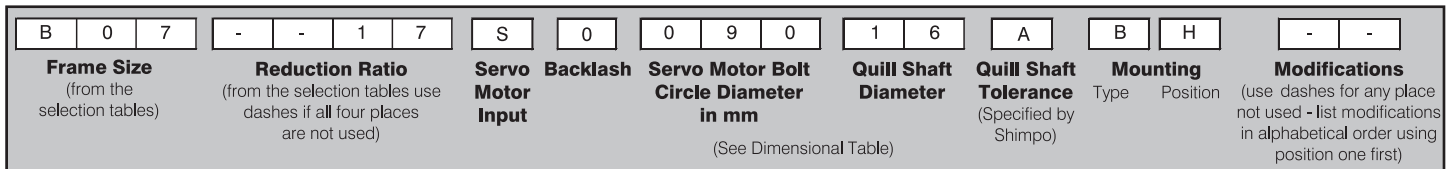

Backlash

Standard Backlash: Approximately 60 arc-min0
 Precision Backlash: Less than 6 arc-minP

Rating Table 1750 rpm Input, Single Reduction, Standard Backlash

Reducer Frame Size	Ratio	11	17	29	35	47	59	71
	Output rpm	159	103	60.3	50.0	37.2	29.7	24.6
A03	Input HP	1.03	0.93	0.58	0.53	0.37	0.28	0.19
	Output lb-in	377	523	556	612	580	552	439
A05 A190	Input HP	1.22	1.09	0.68	0.62	0.44	0.33	0.22
	Output lb-in	443	615	654	720	682	649	517
A07 A195	Input HP	1.43	1.29	0.80	0.73	0.52	0.39	0.26
	Output lb-in	521	724	769	847	802	764	608
B01 B197	Input HP	2.17	1.53	1.08	0.86	0.61	0.48	0.39
	Output lb-in	790	860	1,040	1,000	950	940	910
B03 B100	Input HP	2.72	1.92	1.35	1.08	0.76	0.60	0.48
	Output lb-in	990	1,080	1,300	1,250	1,190	1,170	1,140
B05 B105	Input HP	3.40	2.40	1.70	1.35	0.96	0.75	0.60
	Output lb-in	1,240	1,350	1,630	1,560	1,490	1,460	1,420
B07 B20H	Input HP	4.25	3.00	2.12	1.68	1.19	0.93	0.75
	Output lb-in	1,550	1,690	2,040	1,950	1,860	1,820	1,770
C01	Input HP	5.02	3.87	2.41	2.22	1.53	1.22	1.02
	Output lb-in	1,830	2,180	2,320	2,570	2,390	2,390	2,390
C03 C110	Input HP	6.28	4.83	3.02	2.77	1.92	1.53	1.27
	Output lb-in	2,290	2,720	2,900	3,210	2,990	2,990	2,990
C05 C115	Input HP	7.38	6.43	4.02	3.69	2.56	2.04	1.69
	Output lb-in	2,690	3,620	3,860	4,280	3,990	3,990	3,980
C07 C225	Input HP	8.67	8.02	5.03	4.61	3.20	2.55	2.12
	Output lb-in	3,160	4,520	4,830	5,350	4,990	4,990	4,980
D01	Input HP	10.4	9.84	6.21	5.50	4.10	3.15	2.50
	Output lb-in	3,800	5,540	5,970	6,380	6,380	6,150	5,870
D03 D135	Input HP	13.0	11.6	7.31	6.48	4.82	3.70	2.94
	Output lb-in	4,750	6,520	7,020	7,510	7,510	7,230	6,910
D05 D145	Input HP	16.3	13.6	8.60	7.62	5.68	4.35	3.46
	Output lb-in	5,940	7,670	8,260	8,840	8,840	8,500	8,130
D07 D255	Input HP	20.4	16.0	10.1	8.97	6.68	5.12	4.06
	Output lb-in	7,420	9,020	9,720	10,400	10,400	10,000	9,560
E01	Input HP	24.0	18.8	13.9	11.6	7.71	6.34	4.93
	Output lb-in	8,730	10,600	13,400	13,400	12,000	12,400	11,600
E03 E165	Input HP	26.6	22.2	18.5	15.3	10.3	8.44	6.55
	Output lb-in	9,700	12,500	17,800	17,800	16,000	16,500	15,400
E05 E370	Input HP	31.3	27.7	23.1	19.1	12.8	10.5	8.16
	Output lb-in	11,400	15,600	22,200	22,200	20,000	20,600	19,200
E07 E375	Input HP	39.0	34.6	28.9	24.0	16.1	13.2	10.2
	Output lb-in	14,200	19,500	27,800	27,800	25,000	25,800	24,000
F03	Input HP	45.8	40.3	34.4	30.1	21.8	16.6	13.8
	Output lb-in	16,700	22,700	33,100	34,900	34,000	32,400	32,400
F05	Input HP	51.0	47.4	40.5	35.4	25.7	19.5	16.2
	Output lb-in	18,600	26,700	38,900	41,000	40,000	38,100	38,100
F07	Input HP	60.1	59.3	50.6	44.2	32.1	24.3	20.2
	Output lb-in	21,900	33,400	48,600	51,200	50,000	47,600	47,600

Notes:
Backlash specification is approximately 1° (60 arc-min).

Rating Table 1165 rpm Input, Single Reduction, Standard Backlash

Reducer Frame Size	Ratio	11	17	29	35	47	59	71
	Output rpm	106	68.5	40.2	33.3	24.8	19.7	16.4
A03	Input HP	0.78	0.70	0.44	0.40	0.28	0.21	0.14
	Output lb-in	426	591	628	692	655	624	496
A05 A190	Input HP	0.92	0.82	0.51	0.47	0.33	0.25	0.17
	Output lb-in	501	695	739	814	771	733	584
A07 A195	Input HP	0.95	0.97	0.60	0.55	0.39	0.29	0.19
	Output lb-in	521	818	869	957	906	863	687
B01 B197	Input HP	1.63	1.15	0.82	0.65	0.46	0.36	0.29
	Output lb-in	890	970	1,180	1,130	1,070	1,060	1,030
B03 B100	Input HP	2.05	1.44	1.02	0.81	0.57	0.45	0.37
	Output lb-in	1,120	1,220	1,470	1,410	1,340	1,320	1,290
B05 B105	Input HP	2.56	1.81	1.27	1.01	0.72	0.56	0.45
	Output lb-in	1,400	1,530	1,840	1,760	1,680	1,650	1,600
B07 B20H	Input HP	3.20	2.26	1.60	1.26	0.90	0.70	0.57
	Output lb-in	1,750	1,910	2,310	2,200	2,100	2,060	2,000
C01	Input HP	3.78	2.91	1.82	1.66	1.15	0.92	0.76
	Output lb-in	2,070	2,460	2,620	2,900	2,700	2,700	2,700
C03 C110	Input HP	4.73	3.63	2.27	2.08	1.44	1.15	0.96
	Output lb-in	2,590	3,070	3,280	3,630	3,380	3,380	3,380
C05 C115	Input HP	5.55	4.83	3.02	2.78	1.93	1.54	1.27
	Output lb-in	3,040	4,090	4,360	4,840	4,510	4,510	4,500
C07 C225	Input HP	6.52	6.04	3.78	3.47	2.41	1.92	1.59
	Output lb-in	3,570	5,110	5,460	6,050	5,640	5,640	5,630
D01	Input HP	7.84	7.40	4.68	4.14	3.08	2.37	1.88
	Output lb-in	4,290	6,260	6,750	7,210	7,210	6,950	6,630
D03 D135	Input HP	9.81	8.71	5.49	4.87	3.63	2.78	2.21
	Output lb-in	5,370	7,370	7,930	8,490	8,490	8,170	7,810
D05 D145	Input HP	12.3	10.2	6.46	5.73	4.27	3.27	2.60
	Output lb-in	6,710	8,670	9,330	9,990	9,990	9,610	9,190
D07 D255	Input HP	15.3	11.3	7.62	6.77	5.04	3.85	3.06
	Output lb-in	8,380	9,550	11,000	11,800	11,800	11,300	10,800
E01	Input HP	18.0	14.2	10.5	8.67	5.81	4.77	3.71
	Output lb-in	9,860	12,000	15,100	15,100	13,600	14,000	13,100
E03 E165	Input HP	20.1	16.7	13.9	11.5	7.74	6.33	4.92
	Output lb-in	11,000	14,100	20,100	20,100	18,100	18,600	17,400
E05 E370	Input HP	23.6	20.8	17.4	14.4	9.66	7.93	6.14
	Output lb-in	12,900	17,600	25,100	25,100	22,600	23,300	21,700
E07 E375	Input HP	28.7	26.0	21.6	17.9	12.1	9.94	7.67
	Output lb-in	15,700	22,000	31,200	31,200	28,300	29,200	27,100
F03	Input HP	34.5	30.4	25.9	22.6	16.4	12.5	10.4
	Output lb-in	18,900	25,700	37,400	39,400	38,400	36,600	36,600
F05	Input HP	38.4	35.7	30.5	26.6	19.3	14.7	12.2
	Output lb-in	21,000	30,200	44,000	46,300	45,200	43,100	43,100
F07	Input HP	45.1	44.6	38.0	33.2	24.2	18.3	15.2
	Output lb-in	24,700	37,700	54,900	57,900	56,500	53,800	53,800

Notes:

Backlash specification is approximately 1° (60 arc-min).

Rating Table 1750 rpm Input, Double Reduction, Standard Backlash

Reducer Frame Size	Ratio	121 (11x11)	187 (11x17)	289 (17x17)	319 (11x29)	385 (11x35)	493 (17x29)	517 (11x47)
	Output rpm	14.5	9.36	6.06	5.49	4.55	3.55	3.38
AB3	Input HP	0.36	0.24	0.15	0.19	0.16	0.12	0.12
	Output lb-in	1,340	1,340	1,340	1,820	1,820	1,820	1,820
AB7 AB105	Input HP	0.52	0.34	0.22	0.27	0.22	0.17	0.16
	Output lb-in	1,910	1,910	1,910	2,600	2,600	2,600	2,600
AC3	Input HP	0.72	0.64	0.41	0.44	0.36	0.28	0.27
	Output lb-in	2,670	3,650	3,650	4,260	4,260	4,260	4,260
AC7 AC115	Input HP	1.04	0.91	0.59	0.63	0.52	0.40	0.39
	Output lb-in	3,820	5,210	5,210	6,080	6,080	6,080	6,080
AD3 AD135	Input HP	1.23	1.17	0.85	0.91	0.75	0.59	0.56
	Output lb-in	4,530	6,650	7,460	8,820	8,820	8,820	8,820
AD7 AD145	Input HP	1.42	1.42	1.21	1.30	1.07	0.84	0.80
	Output lb-in	5,240	8,090	10,660	12,600	12,600	12,600	12,600
BD7 BD145	Input HP	2.59	1.68	-	-	-	-	-
	Output lb-in	9,550	9,550	-	-	-	-	-
BE3 BE165	Input HP	2.98	2.89	1.87	2.24	1.86	1.45	1.38
	Output lb-in	11,000	16,500	16,500	21,800	21,800	21,800	21,800
BE7 BE375	Input HP	4.25	4.14	2.68	3.21	2.66	2.08	1.98
	Output lb-in	15,700	23,600	23,600	31,200	31,200	31,200	31,200
CE7 CE375	Input HP	5.88	-	-	-	-	-	-
	Output lb-in	21,700	-	-	-	-	-	-
CF3	Input HP	7.28	6.07	4.14	4.69	3.89	3.03	2.89
	Output lb-in	26,840	34,600	36,500	45,600	45,600	45,600	45,600
CF7	Input HP	8.67	8.67	5.91	6.69	5.55	4.33	4.13
	Output lb-in	32,000	49,400	52,100	65,100	65,100	65,100	65,100
DF7	Input HP	14.1	9.14	-	-	-	-	-
	Output lb-in	52,100	52,100	-	-	-	-	-

Reducer Frame Size	Ratio	595 (17x35)	649 (11x59)	781 (11x71)	799 (17x47)	841 (29x29)	1003 (17x59)	1015 (29x35)
	Output rpm	2.94	2.70	2.24	2.19	2.08	1.74	1.72
AB3	Input HP	0.12	0.12	0.12	0.12	0.12	0.12	0.12
	Output lb-in	1,820	1,820	1,820	1,820	1,820	1,820	1,820
AB7 AB105	Input HP	0.14	0.13	0.12	0.12	0.12	0.12	0.12
	Output lb-in	2,600	2,600	2,600	2,600	2,600	2,600	2,600
AC3	Input HP	0.23	0.22	0.18	0.17	0.17	0.14	0.14
	Output lb-in	4,260	4,260	4,260	4,260	4,260	4,260	4,260
AC7 AC115	Input HP	0.34	0.31	0.26	0.25	0.24	0.20	0.20
	Output lb-in	6,080	6,080	6,080	6,080	6,080	6,080	6,080
AD3 AD135	Input HP	0.49	0.45	0.37	0.36	0.34	0.29	0.29
	Output lb-in	8,820	8,820	8,820	8,820	8,820	8,820	8,820
AD7 AD145	Input HP	0.69	0.64	0.53	0.52	0.49	0.41	0.41
	Output lb-in	12,600	12,600	12,600	12,600	12,600	12,600	12,600
BE3 BE165	Input HP	1.20	1.10	0.92	0.90	0.85	0.71	0.70
	Output lb-in	21,800	21,800	21,800	21,800	21,800	21,800	21,800
BE7 BE375	Input HP	1.72	1.58	1.31	1.28	1.22	1.02	1.01
	Output lb-in	31,200	31,200	31,200	31,200	31,200	31,200	31,200
CF3	Input HP	2.51	2.30	1.92	1.87	1.78	1.49	1.47
	Output lb-in	45,600	45,600	45,600	45,600	45,600	45,600	45,600
CF7	Input HP	3.59	3.29	2.73	2.67	2.54	2.13	2.10
	Output lb-in	65,100	65,100	65,100	65,100	65,100	65,100	65,100

Note:

Input HP shown in the shaded area and in **bold** type is to overcome breakaway torque requirements in cold temperatures or high inertia applications. It is recommended that a torque limiting device is used to protect the unit or driven machine.

Backlash specification is approximately 1° (60 arc-min).

Rating Table 1750 rpm Input, Double Reduction, Standard Backlash

Reducer Frame Size	Ratio	1207 (17x71)	1225 (35x35)	1363 (29x47)	1645 (35x47)	1711 (29x59)	2059 (29x71)	2065 (35x59)
	Output rpm	1.45	1.43	1.28	1.06	1.02	0.85	0.85
AB3	Input HP	0.12	0.12	0.12	0.12	0.12	0.12	0.12
	Output lb-in	1,820	1,820	1,820	1,820	1,820	1,820	1,820
AB7 AB105	Input HP	0.12	0.12	0.12	0.12	0.12	0.12	0.12
	Output lb-in	2,600	2,600	2,600	2,600	2,600	2,600	2,600
AC3	Input HP	0.12	0.12	0.12	0.12	0.12	0.12	0.12
	Output lb-in	4,260	4,260	4,260	4,260	4,260	4,260	4,260
AC7 AC115	Input HP	0.17	0.16	0.15	0.12	0.12	0.12	0.12
	Output lb-in	6,080	6,080	6,080	6,080	6,080	6,080	6,080
AD3 AD135	Input HP	0.24	0.24	0.21	0.18	0.17	0.14	0.14
	Output lb-in	8,820	8,820	8,820	8,820	8,820	8,820	8,820
AD7 AD145	Input HP	0.34	0.34	0.30	0.25	0.24	0.20	0.20
	Output lb-in	12,600	12,600	12,600	12,600	12,600	12,600	12,600
BE3 BE165	Input HP	0.59	0.58	0.52	0.43	0.42	0.35	0.35
	Output lb-in	21,800	21,800	21,800	21,800	21,800	21,800	21,800
BE7 BE375	Input HP	0.85	0.84	0.75	0.62	0.60	0.50	0.50
	Output lb-in	31,200	31,200	31,200	31,200	31,200	31,200	31,200
CF3	Input HP	1.24	1.22	1.10	0.91	0.87	0.73	0.72
	Output lb-in	45,600	45,600	45,600	45,600	45,600	45,600	45,600
CF5	Input HP	1.77	1.74	1.57	1.30	1.25	1.04	1.03
	Output lb-in	65,100	65,100	65,100	65,100	65,100	65,100	65,100

Reducer Frame Size	Ratio	2209 (47x47)	2485 (35x71)	2773 (47x59)	3337 (47x71)	3481 (59x59)	4189 (59x71)	5041 (71x71)
	Output rpm	0.79	0.70	0.63	0.52	0.50	0.42	0.35
AB3	Input HP	0.12	0.12	0.12	0.12	0.12	0.12	0.12
	Output lb-in	1,820	1,820	1,820	1,820	1,820	1,820	1,820
AB7 AB115	Input HP	0.12	0.12	0.12	0.12	0.12	0.12	0.12
	Output lb-in	2,600	2,600	2,600	2,600	2,600	2,600	2,600
AC3	Input HP	0.12	0.12	0.12	0.12	0.12	0.12	0.12
	Output lb-in	4,260	4,260	4,260	4,260	4,260	4,260	4,260
AC7 AC115	Input HP	0.12	0.12	0.12	0.12	0.12	0.12	0.12
	Output lb-in	6,080	6,080	6,080	6,080	6,080	6,080	6,080
AD3 AD135	Input HP	0.13	0.12	0.12	0.12	0.12	0.12	0.12
	Output lb-in	8,820	8,820	8,820	8,820	8,820	8,820	8,820
AD7 AD145	Input HP	0.19	0.17	0.15	0.12	0.12	0.12	0.12
	Output lb-in	12,600	12,600	12,600	12,600	12,600	12,600	12,600
BE3 BE165	Input HP	0.32	0.29	0.26	0.25	0.25	0.25	0.25
	Output lb-in	21,800	21,800	21,800	21,800	21,800	21,800	21,800
BE7 BE375	Input HP	0.46	0.41	0.37	0.31	0.29	0.25	0.25
	Output lb-in	31,200	31,200	31,200	31,200	31,200	31,200	31,200
CF3	Input HP	0.68	0.60	0.54	0.50	0.50	0.50	0.50
	Output lb-in	45,600	45,600	45,600	45,600	45,600	45,600	45,600
CF7	Input HP	0.97	0.86	0.77	0.64	0.61	0.51	0.50
	Output lb-in	65,100	65,100	65,100	65,100	65,100	65,100	65,100

Note:

Input HP shown in the shaded area and in **bold** type is to overcome breakaway torque requirements in cold temperatures or high inertia applications. It is recommended that a torque limiting device is used to protect the unit or driven machine.

Backlash specification is approximately 1° (60 arc-min).

Rating Table 2000 rpm Input, Single Reduction, Standard Backlash

Reducer Frame Size	Ratio	11		17		29		35		47		59		71	
	Output rpm	182		118		69.0		57.1		42.6		33.9		28.2	
A03	Input HP kW	0.92	0.68	0.82	0.61	0.51	0.38	0.47	0.35	0.33	0.25	0.25	0.18	0.17	0.12
	T ₁ lb-in Nm	285	32.3	390	44.5	420	47.4	460	52.2	440	49.7	410	46.8	330	37.5
	T ₂ lb-in Nm	521	58.8	724	81.7	769	86.8	847	95.6	802	90.5	764	86.3	608	68.6
A07	Input HP kW	1.22	0.91	1.09	0.81	0.68	0.51	0.62	0.46	0.44	0.33	0.25	0.22	0.16	
	T ₁ lb-in Nm	381	43.0	530	59.4	560	63.2	620	69.5	590	66.3	550	62.4	440	50.1
	T ₂ lb-in Nm	521	58.8	724	81.7	769	86.8	847	95.6	802	90.5	764	86.3	608	68.6
B03	Input HP kW	2.17	1.62	1.53	1.14	1.08	0.81	0.86	0.64	0.61	0.46	0.48	0.36	0.39	0.29
	T ₁ lb-in Nm	676	76.4	736	83.2	890	101	856	96.7	813	91.9	805	90.9	779	88.0
	T ₂ lb-in Nm	1,690	191	1,840	208	2,230	251	2,140	242	2,030	230	2,010	227	1,950	220
B07	Input HP kW	3.40	2.54	2.40	1.79	1.70	1.27	1.35	1.00	0.96	0.71	0.75	0.56	0.60	0.45
	T ₁ lb-in Nm	1,060	120	1,160	131	1,400	158	1,340	151	1,280	144	1,250	141	1,220	137
	T ₂ lb-in Nm	1,910	216	1,910	216	2,600	294	2,600	294	2,600	294	2,600	294	2,600	294
C03	Input HP kW	5.02	3.75	3.87	2.89	2.41	1.80	2.22	1.65	1.53	1.14	1.22	0.91	1.02	0.76
	T ₁ lb-in Nm	1,570	177	1,870	211	1,990	224	2,200	249	2,050	231	2,050	231	2,050	231
	T ₂ lb-in Nm	3,930	442	4,680	527	4,980	561	5,500	621	5,130	578	5,130	578	5,130	578
C07	Input HP kW	7.38	5.51	6.43	4.79	4.02	3.00	3.69	2.75	2.56	1.91	2.04	1.52	1.69	1.26
	T ₁ lb-in Nm	2,300	260	3,100	350	3,300	373	3,660	414	3,420	386	3,420	386	3,410	385
	T ₂ lb-in Nm	3,820	431	5,210	588	6,080	686	6,080	686	6,080	686	6,080	686	6,080	686
D03	Input HP kW	10.4	7.78	9.84	7.34	6.21	4.64	5.50	4.10	4.10	3.06	3.15	2.35	2.50	1.86
	T ₁ lb-in Nm	3,250	367	4,740	536	5,110	577	5,460	617	5,460	617	5,260	595	5,020	568
	T ₂ lb-in Nm	8,130	919	9,550	1,080	12,600	1,420	12,600	1,420	12,600	1,420	12,600	1,420	12,600	1,420
D07	Input HP kW	16.3	12.16	13.62	10.2	8.60	6.41	7.62	5.69	5.68	4.23	4.35	3.24	3.46	2.58
	T ₁ lb-in Nm	5,080	574	6,570	742	7,070	799	7,570	855	7,570	855	7,280	822	6,960	786
	T ₂ lb-in Nm	9,550	1,080	9,550	1,080	12,600	1,420	12,600	1,420	12,600	1,420	12,600	1,420	12,600	1,420
E03	Input HP kW	24.0	17.9	18.8	14.0	13.9	10.4	11.6	8.65	7.71	5.75	6.34	4.73	4.93	3.68
	T ₁ lb-in Nm	7,490	846	9,100	1,024	11,400	1,290	11,500	1,300	10,300	1,160	10,600	1,200	9,900	1,120
	T ₂ lb-in Nm	15,700	1,770	22,800	2,560	28,500	3,230	28,800	3,250	25,800	2,900	26,500	3,000	24,800	2,800
E07	Input HP kW	31.3	23.3	27.7	20.7	23.1	17.2	19.1	14.2	12.80	9.55	10.5	7.83	8.16	6.09
	T ₁ lb-in Nm	9,760	1,103	13,400	1,510	19,000	2,150	19,000	2,140	17,100	1,930	17,600	1,990	16,400	1,860
	T ₂ lb-in Nm	15,700	1,770	23,600	2,660	31,200	3,520	31,200	3,520	31,200	3,520	31,200	3,520	31,200	3,520
F03	Input HP kW	38.8	28.9	36.0	26.9	30.8	23.0	26.9	20.1	19.5	14.6	14.8	11.06	12.3	9.18
	T ₁ lb-in Nm	12,100	1,366	17,400	1,960	25,300	2,860	26,700	3,020	26,000	2,940	24,800	2,800	24,800	2,800
	T ₂ lb-in Nm	30,300	3,420	43,500	4,900	63,300	7,150	65,100	7,350	65,000	7,340	62,000	7,000	62,000	7,000
F07	Input HP kW	51.0	38.0	47.4	35.4	40.5	30.2	35.4	26.4	25.7	19.2	19.5	14.5	16.2	12.1
	T ₁ lb-in Nm	15,900	1,800	22,900	2,580	33,300	3,760	35,100	3,970	34,300	3,870	32,600	3,690	32,600	3,690
	T ₂ lb-in Nm	39,800	4,500	52,100	5,880	65,100	7,350	65,100	7,350	65,100	7,350	65,100	7,350	65,100	7,350

Notes:

T₁ - Nominal output torque - unit can continuously sustain this torque value without overheating.

T₂ - Emergency stop output torque - unit can sustain this torque value 1000 cycles before breaking.

Acceleration torque is 1.5 times nominal output torque.

Backlash specification is approximately 1° (60 arc-min).

Rating Table 2000 rpm Input, Single Reduction, Precision Backlash (less than 6 arc-min)

Reducer Frame Size	Ratio	11		17		29		35		47		59		71	
	Output rpm	182		118		69.0		57.1		42.6		33.9		28.2	
B03	Input HP kW	1.91	1.43	1.55	1.16	0.96	0.71	0.76	0.56	0.53	0.39	0.43	0.32	0.34	0.25
	T ₁ lb-in Nm	597	67.5	747	84.4	786	88.8	751	84.9	701	79.2	716	80.9	682	77.0
	T ₂ lb-in Nm	1,490	169	1,870	211	1,960	222	1,880	212	1,750	198	1,790	202	1,700	193
B07	Input HP kW	2.55	1.90	2.07	1.54	1.27	0.95	1.01	0.75	0.70	0.52	0.57	0.43	0.45	0.34
	T ₁ lb-in Nm	796	89.9	996	113	1,050	118	1,000	113	935	106	955	108	909	103
	T ₂ lb-in Nm	1,910	216	1,910	216	2,600	294	2,500	283	2,340	264	2,390	270	2,270	257
C03	Input HP kW	3.90	2.91	3.61	2.69	2.26	1.69	2.08	1.55	1.44	1.08	1.15	0.86	0.95	0.71
	T ₁ lb-in Nm	1,220	138	1,740	197	1,860	210	2,060	233	1,920	217	1,920	217	1,920	217
	T ₂ lb-in Nm	3,050	344	4,350	492	4,650	526	5,150	582	4,800	543	4,800	543	4,800	542
C07	Input HP kW	5.20	3.88	4.81	3.59	3.02	2.25	2.77	2.06	1.92	1.43	1.53	1.14	1.27	0.95
	T ₁ lb-in Nm	1,620	183	2,320	262	2,480	280	2,750	310	2,560	290	2,560	290	2,560	289
	T ₂ lb-in Nm	3,820	458	5,210	588	6,080	686	6,080	686	6,080	686	6,080	686	6,080	686
D03	Input HP kW	9.16	6.83	7.21	5.38	4.55	3.40	4.04	3.01	3.01	2.24	2.30	1.72	1.83	1.36
	T ₁ lb-in Nm	2,860	323	3,470	393	3,740	423	4,010	453	4,010	453	3,850	435	3,680	416
	T ₂ lb-in Nm	7,150	807	8,680	981	9,350	1,060	10,000	1,130	10,000	1,130	9,630	1,090	9,200	1,040
D07	Input HP kW	12.2	9.11	9.61	7.17	6.07	4.53	5.38	4.01	4.01	2.99	3.07	2.29	2.44	1.82
	T ₁ lb-in Nm	3,810	431	4,630	523	4,990	564	5,340	603	5,340	603	5,140	580	4,910	555
	T ₂ lb-in Nm	9,530	1,076	9,550	1,080	12,500	1,410	12,600	1,420	12,600	1,420	12,600	1,420	12,300	1,390
E03	Input HP kW	17.5	13.1	15.6	11.6	13.0	9.71	10.8	8.05	7.22	5.39	5.94	4.43	4.59	3.42
	T ₁ lb-in Nm	5,470	618	7,500	849	10,700	1,210	10,700	1,210	9,600	1,090	9,900	1,120	9,200	1,040
	T ₂ lb-in Nm	13,700	1,540	18,800	2,120	26,800	3,030	26,800	3,030	24,000	2,730	24,800	2,800	23,000	2,600
E07	Input HP kW	23.4	17.4	20.8	15.5	17.4	13.0	14.4	10.7	9.63	7.19	7.92	5.91	6.12	4.57
	T ₁ lb-in Nm	7,290	824	10,010	1,130	14,300	1,610	14,300	1,610	12,800	1,450	13,300	1,500	12,300	1,390
	T ₂ lb-in Nm	18,200	2,060	23,600	2,660	31,200	3,520	31,200	3,520	31,200	3,520	31,200	3,520	30,800	3,480
F03	Input HP kW	27.0	20.2	26.7	19.9	22.8	17.0	19.9	14.8	14.4	10.8	11.0	8.17	9.11	6.79
	T ₁ lb-in Nm	8,440	953	12,900	1,450	18,700	2,120	19,700	2,230	19,300	2,180	18,300	2,070	18,300	2,070
	T ₂ lb-in Nm	21,100	2,380	32,300	3,630	46,800	5,300	49,300	5,580	48,300	5,450	45,800	5,180	45,800	5,180
F07	Input HP kW	36.1	26.9	35.6	26.5	30.3	22.6	26.5	19.8	19.3	14.4	14.6	10.9	12.1	9.06
	T ₁ lb-in Nm	11,200	1,270	17,200	1,940	25,000	2,820	26,300	2,970	25,700	2,900	24,400	2,760	24,400	2,760
	T ₂ lb-in Nm	28,000	3,180	43,000	4,850	62,500	7,050	65,100	7,350	65,100	7,350	61,000	6,900	61,000	6,900

Notes:

T₁ - Nominal output torque - unit can continuously sustain this torque value without overheating.

T₂ - Emergency stop output torque - unit can sustain this torque value 1000 cycles before breaking.

Acceleration torque is 1.5 times nominal output torque.

Rating Table 3000 rpm Input, Single Reduction, Standard Backlash

Reducer Frame Size	Ratio	11		17		29		35		47		59		71	
	Output rpm	273		176		103		85.7		63.8		50.8		42.3	
B03	Input HP kW	2.17	1.62	1.53	1.14	1.08	0.81	0.86	0.64	0.61	0.46	0.48	0.36	0.39	0.29
	T ₁ lb-in Nm	451	50.9	491	55.4	593	67.1	571	64.5	542	61.2	536	60.6	432	58.7
	T ₂ lb-in Nm	1,130	127	1,230	139	1,480	168	1,430	161	1,360	153	1,340	152	1,080	147
B07	Input HP kW	3.40	2.54	2.40	1.79	1.70	1.27	1.35	1.00	0.96	0.71	0.75	0.56	0.60	0.45
	T ₁ lb-in Nm	708	79.9	770	87.0	930	105	890	101	850	107	833	105	810	102
	T ₂ lb-in Nm	1,770	200	1,930	218	2,330	263	2,230	251	2,130	267	2,080	261	2,030	254
C03	Input HP kW	5.02	3.75	3.87	2.89	2.41	1.80	2.22	1.65	1.53	1.14	1.22	0.91	1.02	0.76
	T ₁ lb-in Nm	1,040	118	1,240	141	1,320	150	1,470	166	1,360	154	1,360	154	1,360	154
	T ₂ lb-in Nm	2,600	295	3,100	351	3,300	374	3,680	414	3,400	385	3,400	385	3,400	385
C07	Input HP kW	7.38	5.51	6.43	4.79	4.02	3.00	3.69	2.75	2.56	1.91	2.04	1.52	1.69	1.26
	T ₁ lb-in Nm	1,540	173	2,070	233	2,200	249	2,440	276	2,280	286	2,280	286	2,270	285
	T ₂ lb-in Nm	3,850	434	5,180	583	5,500	622	6,100	690	5,700	715	5,700	715	5,680	713
D03	Input HP kW	10.4	7.78	9.84	7.34	6.21	4.64	5.50	4.10	4.10	3.06	3.15	2.35	2.50	1.86
	T ₁ lb-in Nm	2,170	245	3,160	357	3,410	385	3,640	411	3,640	411	3,510	397	3,350	378
	T ₂ lb-in Nm	5,430	612	7,900	893	8,530	962	9,100	1,030	9,100	1,030	8,780	991	8,380	946
D07	Input HP kW	16.3	12.2	13.6	10.2	8.60	6.41	7.62	5.69	5.68	4.23	4.35	3.24	3.46	2.58
	T ₁ lb-in Nm	3,390	383	4,380	495	4,710	533	5,040	570	5,040	633	4,850	609	4,640	582
	T ₂ lb-in Nm	8,480	957	11,000	1,240	11,800	1,330	12,600	1,420	12,600	1,580	12,100	1,520	11,600	1,460

Notes:

T₁ - Nominal output torque - unit can continuously sustain this torque value without overheating.
 T₂ - Emergency stop output torque - unit can sustain this torque value 1000 cycles before breaking.
 Acceleration torque is 1.5 times nominal output torque.
 Backlash specification is approximately 1° (60 arc-min).

Rating Table 3000 rpm Input, Single Reduction, Precision Backlash (less than 6 arc-min)

Reducer Frame Size	Ratio	11		17		29		35		47		59		71	
	Output rpm	273		176		103		85.7		63.8		50.8		42.3	
B03	Input HP kW	1.91	1.43	1.55	1.16	0.96	0.71	0.76	0.56	0.53	0.39	0.43	0.32	0.34	0.25
	T ₁ lb-in Nm	398	45.0	498	56.3	524	59.2	501	56.6	467	52.8	478	54.0	378	51.4
	T ₂ lb-in Nm	1,000	112	1,250	141	1,310	148	1,250	141	1,170	132	1,190	135	940	128
B07	Input HP kW	2.55	1.90	2.07	1.54	1.27	0.95	1.01	0.75	0.70	0.52	0.57	0.43	0.45	0.34
	T ₁ lb-in Nm	531	60.0	664	75.0	698	78.9	668	75.4	623	78.2	637	79.9	606	76.1
	T ₂ lb-in Nm	1,330	150	1,660	188	1,750	197	1,670	189	1,560	196	1,590	200	1,520	190
C03	Input HP kW	3.90	2.91	3.61	2.69	2.26	1.69	2.08	1.55	1.44	1.08	1.15	0.86	0.95	0.71
	T ₁ lb-in Nm	811	91.7	1,160	131	1,240	140	1,370	155	1,280	145	1,280	145	1,280	144
	T ₂ lb-in Nm	2,030	229	2,900	328	3,100	350	3,430	388	3,200	362	3,200	362	3,200	361
C07	Input HP kW	5.20	3.88	4.81	3.59	3.02	2.25	2.77	2.06	1.92	1.43	1.53	1.14	1.27	0.95
	T ₁ lb-in Nm	1,080	122	1,550	175	1,650	187	1,830	207	1,710	214	1,710	214	1,710	214
	T ₂ lb-in Nm	2,700	306	3,880	437	4,130	467	4,580	517	4,280	536	4,280	536	4,280	535
D03	Input HP kW	9.16	6.83	7.21	5.38	4.55	3.40	4.04	3.01	3.01	2.24	2.30	1.72	1.83	1.36
	T ₁ lb-in Nm	1,910	215	2,320	262	2,500	282	2,670	302	2,670	302	2,570	290	2,450	277
	T ₂ lb-in Nm	4,780	538	5,800	654	6,250	705	6,680	754	6,680	754	6,430	725	6,130	693
D07	Input HP kW	12.2	9.11	9.61	7.17	6.07	4.53	5.38	4.01	4.01	2.99	3.07	2.29	2.44	1.82
	T ₁ lb-in Nm	2,540	287	3,090	349	3,330	376	3,560	402	3,560	447	3,420	430	3,270	411
	T ₂ lb-in Nm	6,350	718	7,730	872	8,330	940	8,900	1,010	8,900	1,120	8,550	1,070	8,180	1,030

Notes:

T₁ - Nominal output torque - unit can continuously sustain this torque value without overheating.
 T₂ - Emergency stop output torque - unit can sustain this torque value 1000 cycles before breaking.
 Acceleration torque is 1.5 times nominal output torque.

Internal Inertia (WK²) Reflected to the Input Shaft

Unit: lb ft²

Reducer Frame Size	Input Type	Reduction Ratio						
		11	17	29	35	47	59	71
A	All	0.0013	0.0016	0.0015	0.0015	0.0015	0.0015	0.0015
B	All	0.0017	0.0023	0.0022	0.0022	0.0022	0.0022	0.0022
C	All	0.0074	0.0081	0.0099	0.0098	0.0097	0.0097	0.0097
D	All	0.0184	0.0261	0.0285	0.0279	0.0279	0.0279	0.0273
E	C-Face, Servo, Coupling Adaptor, Shovel Base Shaft Input, Top Mount	0.0748	0.1250	0.1170	0.1160	0.1150	0.1150	0.1140
		0.3140	0.3680	0.3560	0.3560	0.3560	0.3560	0.3560
F	C-Face, Servo, Coupling Adaptor, Shovel Base Shaft Input, Top Mount	0.2080	0.1780	0.3090	0.3030	0.3030	0.3030	0.2970
		0.7710	0.7120	0.8310	0.8310	0.8310	0.8310	0.8310

Torsional Stiffness Precision Backlash Units

Reducer Frame Size	Ratio	11	17	29	35	47	59	71
B	in-lbs/arc-min	26.9	41.6	43.9	48.1	48.1	48.1	48.1
	Nm/arc-min	3.0	4.7	5.0	5.4	5.4	5.4	5.4
C	in-lbs/arc-min	54.4	98.9	105	111	111	111	111
	Nm/arc-min	6.2	11.2	11.9	12.6	12.6	12.6	12.6
D	in-lbs/arc-min	157	203	223	242	242	242	242
	Nm/arc-min	17.8	23.0	25.2	27.4	27.4	27.4	27.4
E	in-lbs/arc-min	485	622	753	753	753	753	753
	Nm/arc-min	54.8	70.4	85.2	85.2	85.2	85.2	85.2
F	in-lbs/arc-min	1,030	1,080	1,180	1,180	1,180	1,180	1,180
	Nm/arc-min	117	122	133	133	133	133	133

Notes:

Torsional stiffness of standard backlash units is higher than precision backlash units. Contact Shimpo Drives Customer Service for additional information.

Standard Lubrication

Single Reduction

Reducer Frame Size	Input Speed (rpm)	All Output Shaft Positions	Maximum Input Speed (rpm)
A	≤ 2000	Grease	2000
B	≤ 2000	Grease	3600
	>2000 or Servo Input	Oil	
C	≤ 2000	Grease	3600
	>2000 or Servo Input	Oil	
D	Any	Oil	3600
E	Any	Oil	2000
F	Any	Oil	2000

Notes:

Oil lubrication for B01 - C07 for non-servo motor applications is available upon request. Consult Maintenance, Parts, & Instruction Manual for specific lubrication recommendations.

Standard Lubrication

Double Reduction

Reducer Frame Size	Output Shaft Position		
	Horizontal	Vertical Down	Vertical Up
AB3, AB7, AB105 AC3, AC7, AC115	Grease	Grease	Grease
AD3, AD7, AD135, AD145 BD7	Oil	Grease	Oil
BE3, BE7, BE165, BE375 CE7	Oil	Grease	Oil
CF3, CF7 DF7	Oil	Grease Oil	Oil

Notes:

Lubrication type is based on 1750 RPM input. Consult Maintenance, Parts, & Instruction Manual for specific lubrication recommendations.

Common Dimensions Single Reduction Base Mount

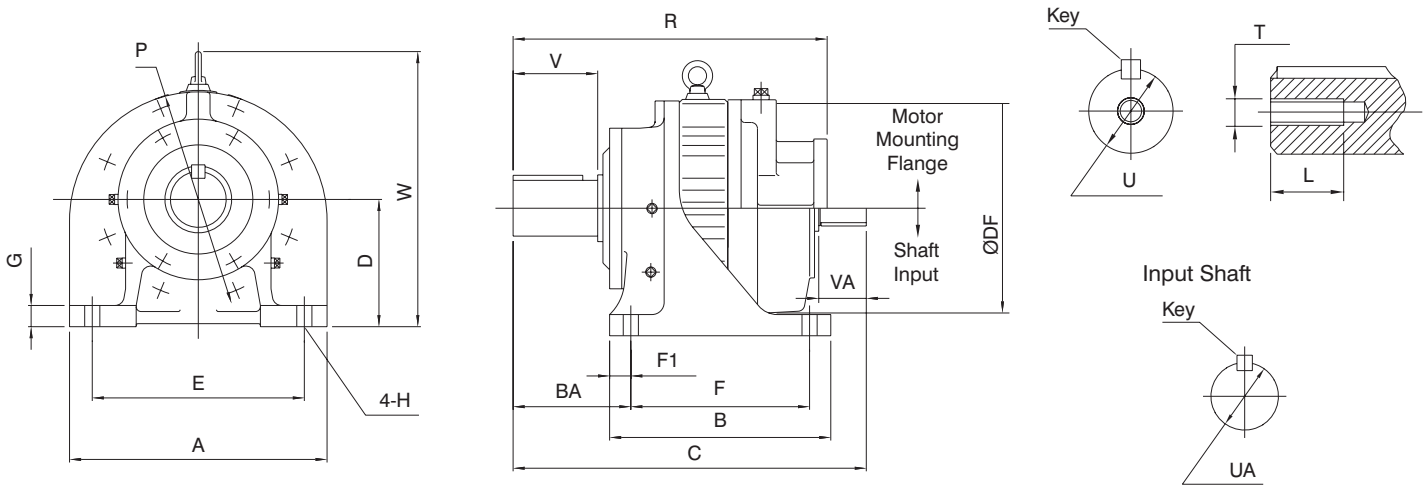

Reducer Frame Size	A	B	BA	C	D	DF	E	F	F1	G	H	P
A03 - A07	6.89	4.72	2.57	8.36	3.543	N/A	5.71	3.54	0.59	0.63	0.47	5.79
A190 - A195	7.09	5.31	2.36	9.16	3.937	N/A	5.91	3.54	0.59	0.47	0.43	5.79
B01 - B07	6.89	5.91	3.38	10.47	4.528	N/A	5.71	4.72	0.59	0.63	0.47	5.91
B195 - B105	7.09	5.31	2.36	9.85	3.937	N/A	5.91	3.54	0.59	0.47	0.43	5.91
B20H	7.09	5.31	2.36	9.85	4.724	N/A	5.91	3.54	0.59	0.47	0.43	5.91
C01 - C07	8.66	7.48	4.07	12.72	5.512	N/A	7.09	5.91	0.79	0.87	0.59	7.48
C110 - C115	9.06	6.10	3.23	12.39	4.724	N/A	7.48	4.53	0.79	0.59	0.55	7.48
C225	9.06	6.10	3.23	12.39	5.512	N/A	7.48	4.53	0.79	0.59	0.55	7.48
D01 - D07	10.83	9.06	5.33	14.17	6.496	N/A	8.86	7.09	0.98	1.02	0.75	9.25
D135	13.00	7.68	3.94	13.18	5.905	N/A	11.42	5.71	0.98	0.87	0.71	9.25
D145	13.00	7.68	4.72	13.96	5.905	N/A	11.42	5.71	0.98	0.87	0.71	9.25
D225	13.00	7.68	4.72	13.96	6.299	N/A	11.42	5.71	0.98	0.87	0.71	9.25
E01 - E07	14.17	11.81	5.94	19.49	7.283	12.32	11.81	9.84	0.98	1.18	0.87	11.81
E165	16.14	9.37	5.47	18.66	6.299	12.32	14.56	5.91	1.73	0.98	0.71	11.81
E370 - E375	16.93	13.19	4.92	18.66	7.874	12.32	14.96	10.83	1.18	1.18	0.87	16.30
F03 - F07	16.73	14.37	7.67	22.95	8.268	14.49	13.78	11.61	1.38	1.38	0.98	14.17

Common Dimensions Single Reduction Base Mount

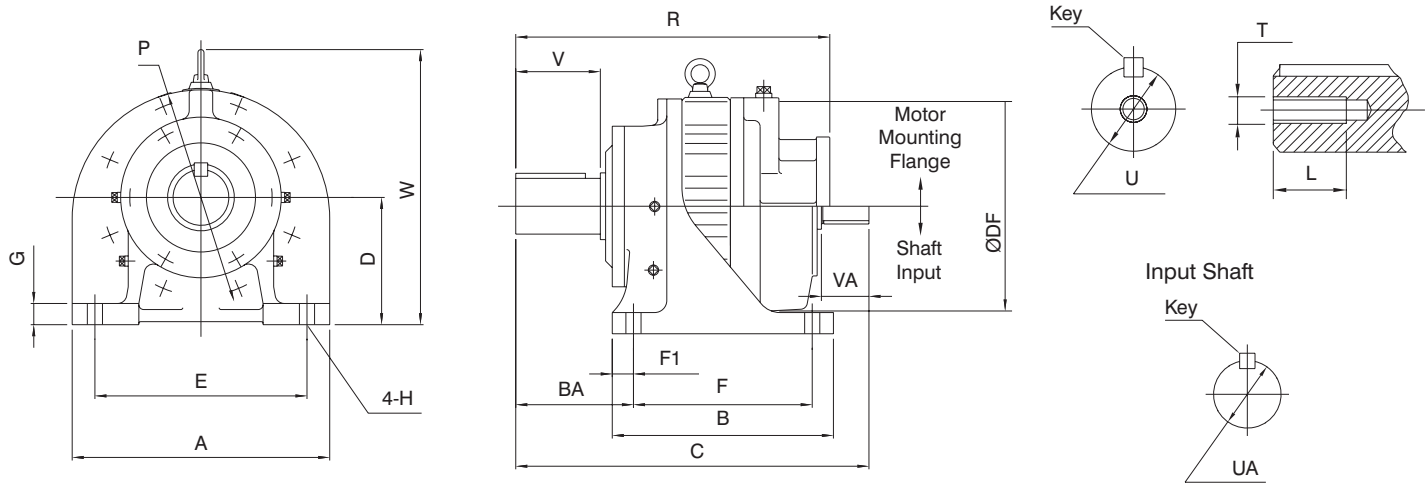

Reducer Frame Size	W	Output Shaft					Input Shaft			Net Weight Shaft Input (lb)
		U	V	Key	T	L	UA	VA	Key	
A03 - A07	6.44	0.875	1.19	.188x.188x.98	N/A	N/A	0.750	1.19	.188x.188x.98	20
A190 - A195	6.84	1.125	1.38	.250x.250x1.18	N/A	N/A	0.750	1.19	.188x.188x.98	30
B01 - B07	7.48	1.375	2.00	.313x.313x1.77	N/A	N/A	0.750	1.19	.188x.188x.98	29
B195 - B105	6.89	1.125	1.38	.250x.250x1.18	N/A	N/A	0.750	1.19	.188x.188x.98	34
B20H	7.68	1.125	1.38	.250x.250x1.18	N/A	N/A	0.750	1.19	.188x.188x.98	35
C01 - C07	10.38	1.750	2.50	.375x.375x2.16	N/A	N/A	1.000	1.56	.250x.250x1.25	64
C110 - C115	9.59	1.500	2.17	.375x.375x1.77	N/A	N/A	1.000	1.56	.250x.250x1.25	56
C225	10.38	1.500	2.17	.375x.375x1.77	N/A	N/A	1.000	1.56	.250x.250x1.25	58
D01 - D07	12.68	2.500	3.75	.625x.625x2.95	3/8-16UNC	0.71	1.125	1.75	.250x.250x1.37	117
D135	12.17	1.875	2.76	.500x.500x2.17	3/8-16UNC	0.71	1.125	1.75	.250x.250x1.37	104
D145	12.17	1.875	3.54	.500x.500x2.95	3/8-16UNC	0.71	1.125	1.75	.250x.250x1.37	104
D225	12.56	1.875	3.54	.500x.500x2.95	3/8-16UNC	0.71	1.125	1.75	.250x.250x1.37	104
E01 - E07	15.71	2.875	4.37	.750x.750x3.74	3/4-10UNC	1.38	1.625	2.56	.375x.375x2.36	227
E165	14.73	2.250	3.54	.500x.500x2.95	3/8-16UNC	0.71	1.625	2.56	.375x.375x2.36	226
E370 - E375	16.30	2.750	3.54	.625x.625x2.95	1/2-13UNC	0.94	1.625	2.56	.375x.375x2.36	260
F03 - F07	17.89	3.625	5.50	.875x.875x4.53	3/4-10UNC	1.38	1.875	3.00	.500x.500x2.95	403

Notes:
 Other mounting styles available. Contact Shimpo Drives Customer Service for additional information.
 Sizes A through B do not have a lifting eye.
 Dimensions subject to change without notice.

All dimensions are shown in inches.
 N/A - denotes dimension not applicable.
 To download CAD drawings, visit our website: www.shimpodrives.com.
 See page 20 for C-Face dimensions.

Motor Flange Dimensions Single Reduction Base Mount

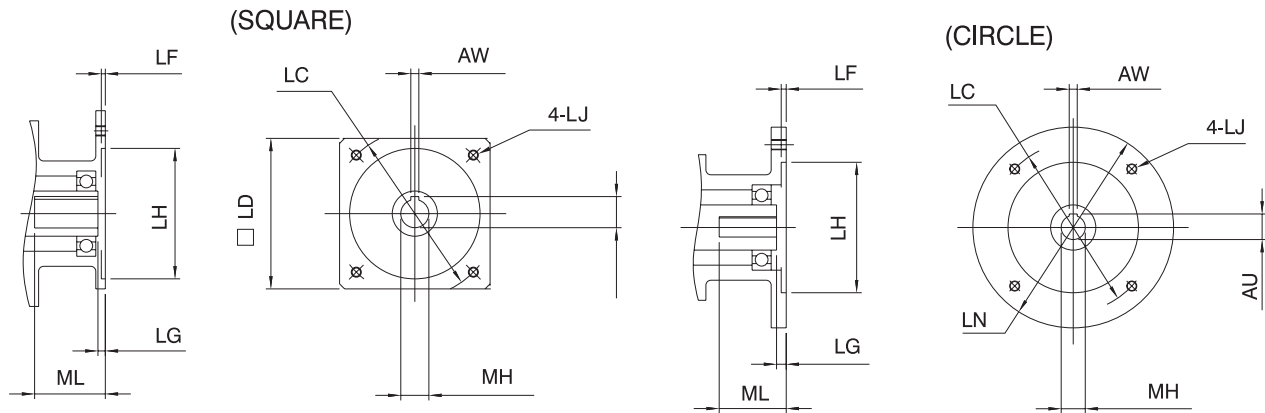

Servo Input

Reducer Frame Size	LC	LD	LF	LG	LH	LN	LJ	MH	R	Net Weight (lb)
A03, A07	70	---	5	5	50	120	M5	14, 16	203	22
	90	---	5	7	70	120	M6	16, 19	213	22
	100	---	7	7	80	120	M6	16, 19	215	22
	115	100	7	7	95	---	M6	19, 24	213	22
	145	110	7	8	110	---	M8	22, 24	213	28
B03, B07	70	---	5	5	50	120	M5	14, 16	238	36
	90	---	5	7	70	120	M6	16, 19	248	36
	100	---	7	7	80	120	M6	16, 19	250	36
	115	100	7	7	95	---	M6	19, 24	248	36
	145	110	7	8	110	---	M8	22, 24	248	38
C03, C07	90	---	7	7	70	160	M6	16	294	68
	100	---	7	7	80	120	M6	16, 19	301	68
	115	130	7	7	95	---	M6	22, 24	294	68
	145	130	7	8	110	---	M8	24, 28	294	68
	200	176	7	7	114.3	---	M12	28, 35	329	85
D03, D07	115	---	7	7	95	200	M6	22, 24	354	115
	145	130	8	8	110	---	M8	22, 24	349	115
	165	---	8	8	130	200	M10	24, 28	361	115
	200	176	10	7	114.3	---	M12	28, 35	379	125
	215	---	10	10	180	300	M12	35, 38	399	135
E03, E07	145	---	10	7	110	250	M8	24, 28	410	246
	165	176	7	7	130	---	M12	24, 28	399	224
	200	176	7	6	114.3	---	M12	28, 35	399	224
	215	---	10	11	180	300	M12	35, 38	460	257
	235	---	8	11	200	350	M12	38, 42	494	286
F03, F07	200	---	10	7	114.3	300	M12	28, 35	546	458
	215	---	10	8	180	300	M12	35, 38	546	458
	235	---	5	11	200	300	M12	38, 42	546	458
	265	---	5	11	230	400	M12	42, 48	565	484

MH	AU	AW	ML
14	16	5	32
16	18	5	37
19	21.5	6	42
22	25	8	57
24	27	8	67
28	31	8	67
35	38	10	67
38	41	10	88
42	45	12	118
48	51.5	14	118

Notes:

Other servo flanges and bore sizes are available. Contact Shimpo Drives Customer Service for additional information.

All dimensions are in mm.

To download CAD drawings, visit our website: www.shimpodrives.com.

Dimensions subject to change without notice.

Motor Flange Dimensions Single Reduction Base Mount

C-Face Input

Reducer Frame Size	C-Face Motor Size	R	Net Weight (lbs)
A03 - A07	56C/140TC	7.88	22
A190 - A195	56C/140TC	8.69	32
B01 - B07	56C/140TC	9.99	35
	180TC	10.78	42
B195 - B105	56C/140TC	9.37	36
B20H	56C/140TC	9.37	36
	180TC	10.16	47
C01 - C07	56C/140TC	11.71	73
	180TC	12.30	76
	210TC	13.45	96
C110 - C115	56C/140TC	11.38	68
	180TC	11.97	72
	210TC	13.15	92
C225	56C/140TC	11.38	70
	180TC	11.97	74
	210TC	13.15	94
D01 - D07	140TC	13.56	135
	180TC	14.15	138
	210TC	14.74	140
	250TC	15.33	150
D135	140TC	12.57	105
	180TC	13.16	115
	210TC	13.75	125
	250TC	14.34	135
D145/D225	180TC	13.94	115
	210TC	14.53	125
	250TC	15.12	135
E01 - E07	180TC/210TC/250TC	17.87	255
	280TC	19.44	270
E165	180TC/210TC/250TC	17.05	233
	280TC	18.62	255
E370 - E375	180TC/210TC/250TC	17.05	278
	280TC	18.62	288
F03 - F07	210TC/250TC	20.42	414
	280TC	21.84	447
	320TC	23.58	502

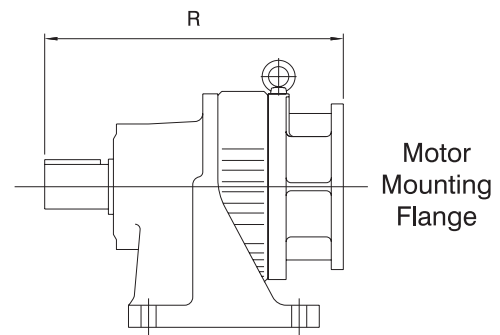

Common Dimensions Single Reduction Flange Mount

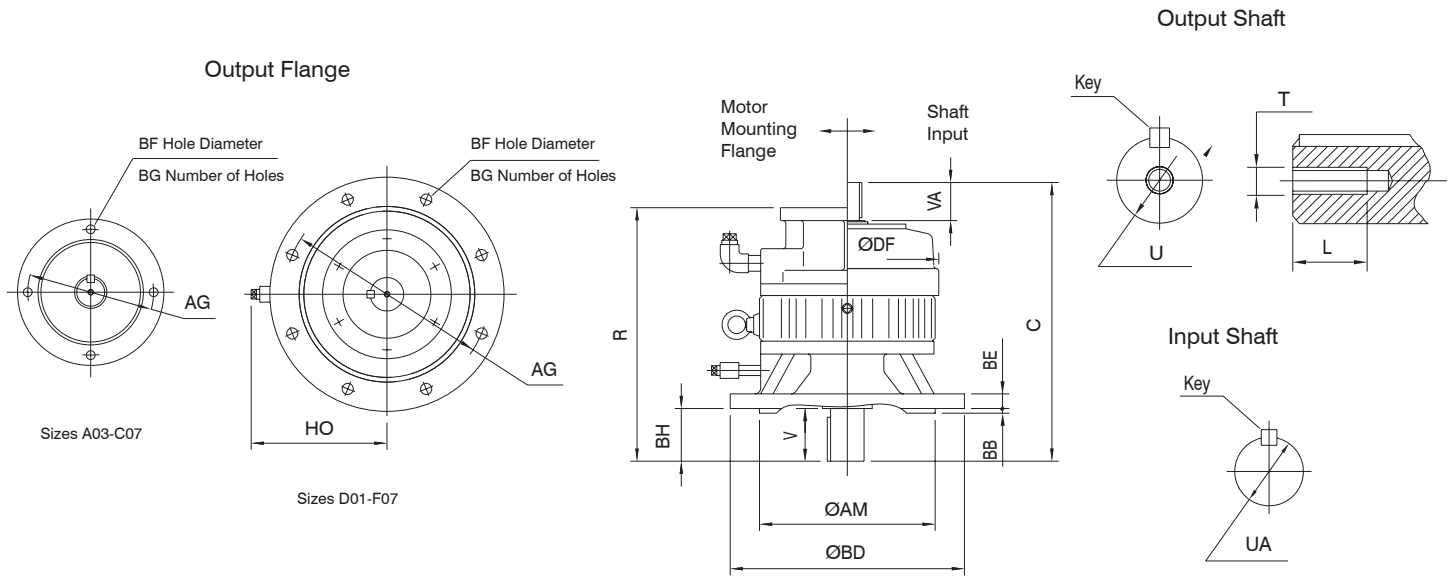

Reducer Frame Size	AG	AM	BB	BD	BE	BF	BG	BH	C	DF	HO
A03 - A07	5.12	4.331	0.16	6.30	0.55	0.47	4	1.18	8.36	N/A	N/A
B01 - B07	6.50	5.118	0.16	7.87	0.55	0.47	4	1.58	10.47	N/A	N/A
C01 - C07	8.46	7.087	0.16	9.84	0.71	0.59	4	2.17	12.72	N/A	N/A
D01 - D07	10.43	9.055	0.20	11.81	0.87	0.59	8	2.76	14.17	N/A	7.28
E01 - E07	13.78	11.811	0.31	15.75	0.98	0.75	8	3.54	19.49	12.32	9.06
F03 - F07	15.75	13.780	0.31	17.72	0.98	0.75	8	4.33	22.95	14.49	10.24

Reducer Frame Size	Output Shaft					Input Shaft			Net Weight Shaft Input (lb)
	U	V	Key	T	L	UA	VA	Key	
A03 - A07	0.875	1.19	.188x.188x.98	N/A	N/A	0.750	1.19	.188x.188x.98	20
B01 - B07	1.375	2.00	.313x.313x1.77	N/A	N/A	0.750	1.19	.188x.188x.98	29
C01 - C07	1.750	2.50	.375x.375x2.16	N/A	N/A	1.000	1.56	.250x.250x1.25	64
D01 - D07	2.500	3.75	.625x.625x2.95	3/8-16UNC	0.71	1.125	1.75	.250x.250x1.37	106
E01 - E07	2.875	4.37	.750x.750x3.74	3/4-10UNC	1.38	1.625	2.56	.375x.375x2.36	199
F03 - F07	3.625	5.50	.875x.875x4.53	3/4-10UNC	1.38	1.875	3.00	.500x.500x2.95	392

Notes:
 All dimensions are in inches.
 To download CAD drawings, visit our website: www.shimpodrives.com.
 N/A – denotes dimension not applicable.

See page 21 for "R" dimensions.
 See page 28 for C-Face dimensions.
 Dimensions subject to change without notice.

Motor Flange Dimensions Single Reduction Flange Mount

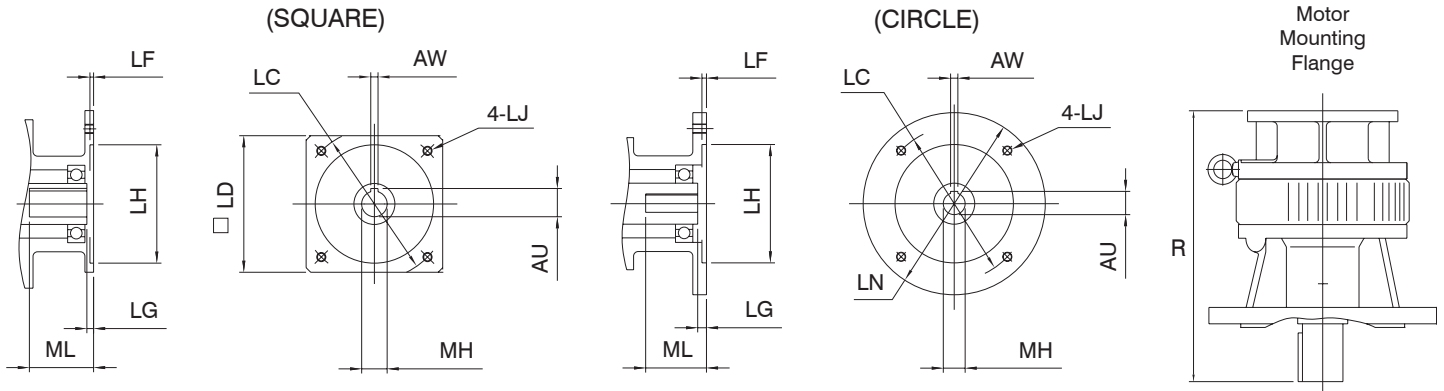

Servo Input

Reducer Frame Size	LC	LD	LF	LG	LH	LN	LJ	MH	R	Net Weight (lb)
A03, A07	70	---	5	5	50	120	M5	14, 16	203	22
	90	---	5	7	70	120	M6	16, 19	213	22
	100	---	7	7	80	120	M6	16, 19	215	22
	115	100	7	7	95	---	M6	19, 24	213	22
	145	110	7	8	110	---	M8	22, 24	213	22
B03, B07	70	---	5	5	50	120	M5	14, 16	238	36
	90	---	5	7	70	120	M6	16, 19	248	36
	100	---	7	7	80	120	M6	16, 19	250	36
	115	100	7	7	95	---	M6	19, 24	248	36
	145	110	7	8	110	---	M8	22, 24	248	38
C03, C07	90	---	7	7	70	160	M6	16	294	68
	100	---	7	7	80	120	M6	16, 19	301	68
	115	130	7	7	95	---	M6	22, 24	294	68
	145	130	7	8	110	---	M8	24, 28	294	68
	200	176	7	7	114.3	---	M12	28, 35	329	85
D03, D07	115	---	7	7	95	200	M6	22, 24	354	115
	145	130	8	8	110	---	M8	22, 24	349	115
	165	---	8	8	130	200	M10	24, 28	361	115
	200	176	10	7	114.3	---	M12	28, 35	379	125
	215	---	10	10	180	300	M12	35, 38	399	135
E03, E07	145	---	10	7	110	250	M8	24, 28	410	246
	165	176	7	7	130	---	M12	24, 28	399	224
	200	176	7	6	114.3	---	M12	28, 35	399	224
	215	---	10	11	180	300	M12	35, 38	460	257
	235	---	8	11	200	350	M12	38, 42	494	286
F03, F07	200	---	10	7	114.3	300	M12	28, 35	546	458
	215	---	10	8	180	300	M12	35, 38	546	458
	235	---	5	11	200	300	M12	38, 42	546	458
	265	---	5	11	230	400	M12	42, 48	565	484

MH	AU	AW	ML
14	16	5	32
16	18	5	37
19	21.5	6	42
22	25	8	57
24	27	8	67
28	31	8	67
35	38	10	67
38	41	10	88
42	45	12	118
48	51.5	14	118

C-Face Input

Reducer Frame Size	C-Face Motor Size	R	Net Weight (lb)
A03 - A07	56C/140TC	7.88	22
	180TC	10.78	42
B01 - B07	56C/140TC	9.99	35
	180TC	10.78	42
C01 - C07	56C/140TC	11.71	73
	180TC	12.30	76
	210TC	13.45	96
D01 - D07	140TC	13.56	135
	180TC	14.15	138
	210TC	14.74	140
	250TC	15.33	150
E01 - E07	180TC	17.87	244
	210TC	17.87	244
	250TC	17.87	244
	280TC	19.44	259
F03 - F07	210TC	20.42	386
	250TC	20.42	386
	280TC	21.84	419
	320TC	23.58	474

Notes:
 Other servo flanges and bore sizes are available. Contact Shimpo Drives Customer Service for additional information.
 All dimensions are in mm.
 To download CAD drawings, visit our website: www.shimpodrives.com.
 Dimensions subject to change without notice.

Notes:
 All dimensions are in inches.
 See page 28 for remaining C-Face dimensions.
 Dimensions subject to change without notice.

Common Dimensions Single Reduction Ring Mount

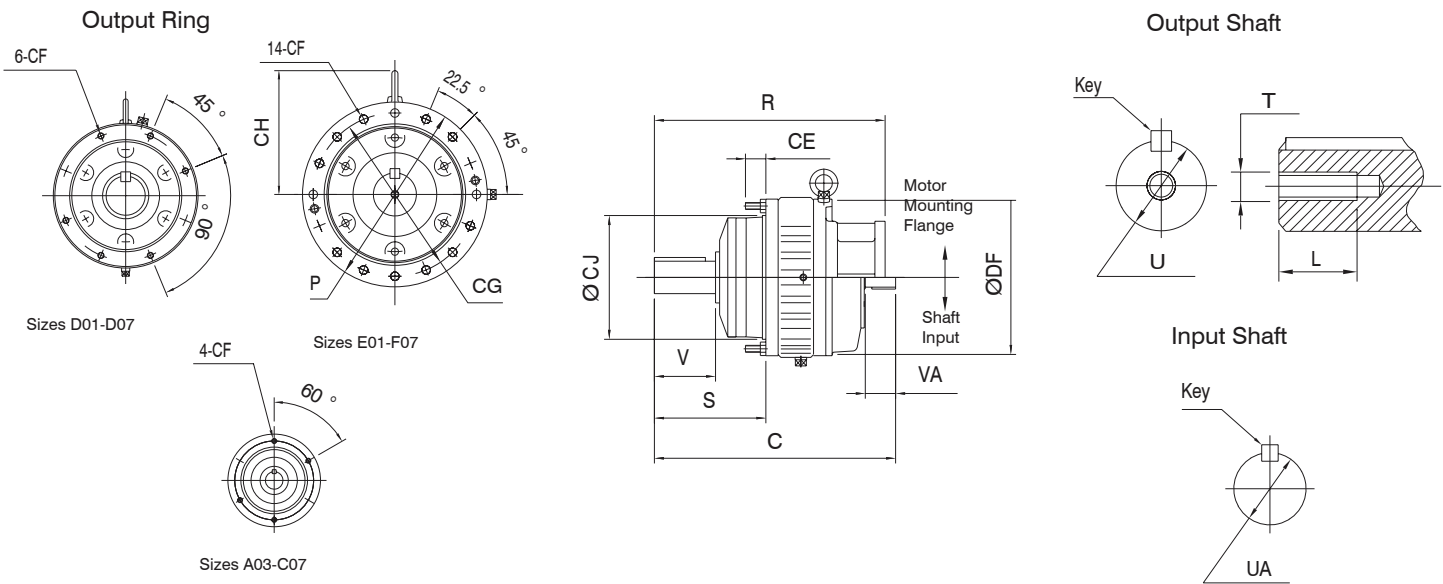

Reducer Frame Size	C	CE	CF	CG	CH	CJ	DF	P	S	Net Weight Shaft Input (lb)
A03 - A07	8.36	0.94	M8	5.04	N/A	4.252	N/A	5.79	3.67	18
B01 - B07	10.47	0.94	M8	5.04	N/A	4.252	N/A	5.91	4.99	24
C01 - C07	12.72	1.38	M10	6.38	4.96	5.354	N/A	7.48	6.20	54
D01 - D07	14.17	1.18	M10	8.27	6.18	7.165	N/A	9.25	6.67	89
E01 - E07	19.49	1.57	M12	10.43	7.91	9.055	12.32	11.81	8.03	178
F03 - F07	22.95	1.38	M12	12.80	9.09	11.417	14.49	14.17	9.83	321

Reducer Frame Size	Output Shaft					Input Shaft		
	U	V	Key	T	L	UA	VA	Key
A03 - A07	0.875	1.19	.188x.188x.98	N/A	N/A	0.750	1.19	.188x.188x.98
B01 - B07	1.375	2.00	.313x.313x1.77	N/A	N/A	0.750	1.19	.188x.188x.98
C01 - C07	1.750	2.50	.375x.375x2.16	N/A	N/A	1.000	1.56	.250x.250x1.25
D01 - D07	2.500	3.75	.625x.625x2.95	3/8-16UNC	0.71	1.125	1.75	.250x.250x1.37
E01 - E07	2.875	4.37	.750x.750x3.74	3/4-10UNC	1.38	1.625	2.56	.375x.375x2.36
F03 - F07	3.625	5.50	.875x.875x4.53	3/4-10UNC	1.38	1.875	3.00	.500x.500x2.95

Notes:

All dimensions are in inches.

To download CAD drawings, visit our website: www.shimpodrives.com.

N/A - denotes dimension not applicable.

See page 23 for "R" dimensions.

See page 28 for C-Face dimensions.

Dimensions subject to change without notice.

Motor Flange Dimensions Single Reduction Ring Mount

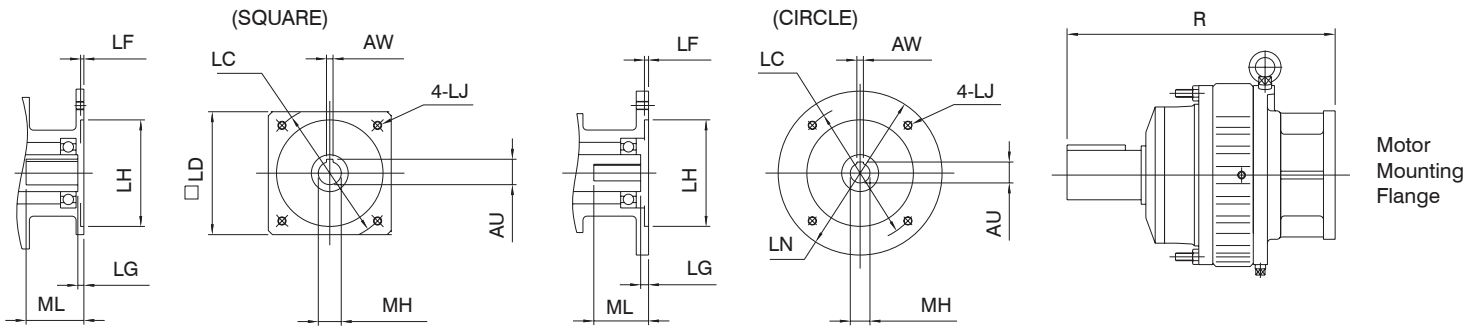

Servo Input

Reducer Frame Size	LC	LD	LF	LG	LH	LN	LJ	MH	R	Net Weight (lb)
A03, A07	70	---	5	5	50	120	M5	14, 16	203	20
	90	---	5	7	70	120	M6	16, 19	213	20
	100	---	7	7	80	120	M6	16, 19	215	20
	115	100	7	7	95	---	M6	19, 24	213	20
	145	110	7	8	110	---	M8	22, 24	213	26
B03, B07	70	---	5	5	50	120	M5	14, 16	238	31
	90	---	5	7	70	120	M6	16, 19	248	31
	100	---	7	7	80	120	M6	16, 19	250	31
	115	100	7	7	95	---	M6	19, 24	248	31
	145	110	7	8	110	---	M8	22, 24	248	33
C03, C07	90	---	7	7	70	160	M6	16	294	58
	100	---	7	7	80	120	M6	16, 19	301	58
	115	130	7	7	95	---	M6	22, 24	294	58
	145	130	7	8	110	---	M8	24, 28	294	58
	200	176	7	7	114.3	---	M12	28, 35	329	75
D03, D07	115	---	7	7	95	200	M6	22, 24	354	90
	145	130	8	8	110	---	M8	22, 24	349	90
	165	---	8	8	130	200	M10	24, 28	361	90
	200	176	10	7	114.3	---	M12	28, 35	379	100
	215	---	10	10	180	300	M12	35, 38	399	110
E03, E07	145	---	10	7	110	250	M8	24, 28	410	197
	165	176	7	7	130	---	M12	24, 28	399	175
	200	176	7	6	114.3	---	M12	28, 35	399	175
	215	---	10	11	180	300	M12	35, 38	460	208
	235	---	8	11	200	350	M12	38, 42	494	237
F03, F07	200	---	10	7	114.3	300	M12	28, 35	546	376
	215	---	10	8	180	300	M12	35, 38	546	376
	235	---	5	11	200	300	M12	38, 42	546	376
	265	---	5	11	230	400	M12	42, 48	565	402

MH	AU	AW	ML
14	16	5	32
16	18	5	37
19	21.5	6	42
22	25	8	57
24	27	8	67
28	31	8	67
35	38	10	67
38	41	10	88
42	45	12	118
48	51.5	14	118



C-Face Input

Reducer Frame Size	C-Face Motor Size	R	Net Weight (lb)
A03 - A07	56C/140TC	7.88	20
	180TC	10.78	36
B01 - B07	56C/140TC	9.99	29
	180TC	12.30	67
	210TC	13.45	87
C01 - C07	56C/140TC	11.71	64
	180TC	13.56	107
	210TC	14.15	110
D01 - D07	140TC	14.74	112
	180TC	15.33	122
	210TC	17.87	206
E01 - E07	180TC	17.87	206
	210TC	17.87	206
	250TC	19.44	221
F03 - F07	210TC	20.42	332
	250TC	20.42	332
	280TC	21.84	365
	320TC	23.58	420

Notes:
 Other servo flanges and bore sizes are available. Contact Shimpo Drives Customer Service for additional information.
 All dimensions are in mm.
 To download CAD drawings, visit our website: www.shimpodrives.com.
 Dimensions subject to change without notice.

Notes:
 All dimensions are in inches.
 See page 28 for C-Face dimensions.

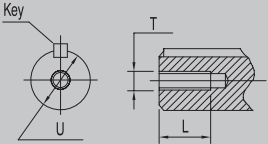
Dimensions Double Reduction All Mounting Types

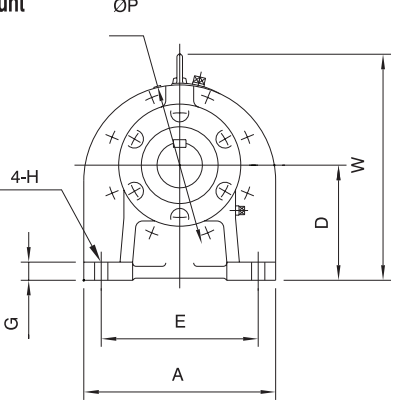
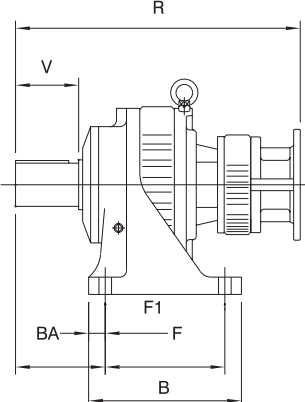
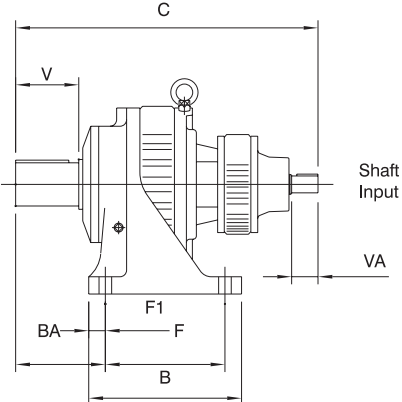
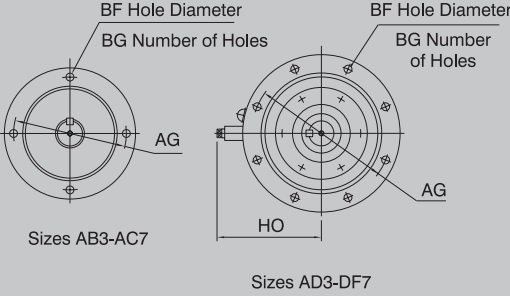
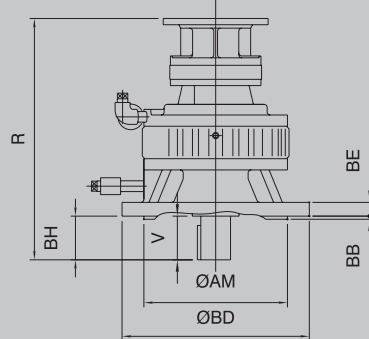
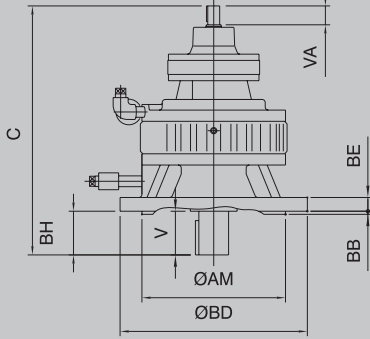
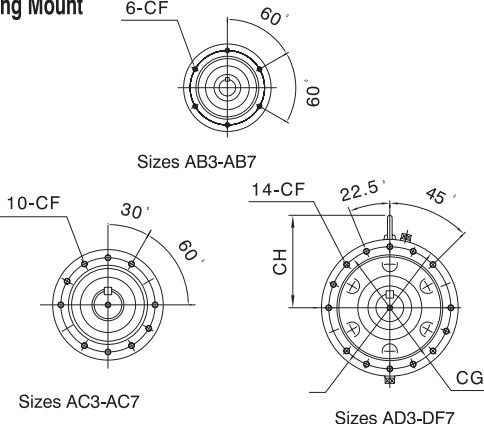
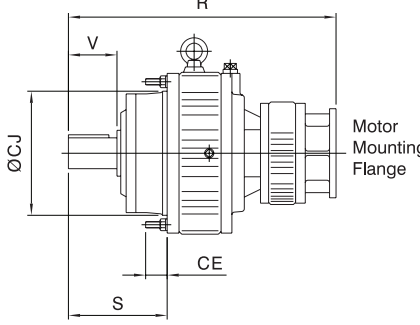
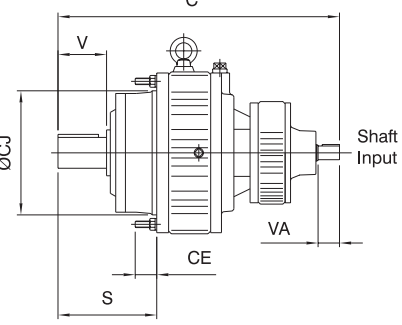
<p>Output Shaft</p> 	<p>NEMA C-Face Input</p>	<p>Input Shaft</p> 
<p>Base Mount</p> 	<p>NEMA C-Face Input</p>  <p>Motor Mounting Flange</p>	<p>Input Shaft</p>  <p>Shaft Input</p>
<p>Flange Mount</p> 	<p>Motor Mounting Flange</p> 	<p>Shaft Input</p> 
<p>Ring Mount</p> 	<p>Motor Mounting Flange</p> 	<p>Shaft Input</p> 

Dimensions Double Reduction All Mounting Types

Reducer Frame Size	C-Face Motor	A	AG	AM	B	BA	BB	BD	BE	BF	BH	BG	C	CE
AB3, AB7	56C	6.89	6.50	5.118	5.91	3.38	0.16	7.87	0.55	0.47	2.00	4	13.15	0.94
AB105	56C	7.09	6.50	5.118	5.31	3.54	0.16	7.87	0.55	0.47	1.38	4	12.51	0.94
AC3, AC7	56C	8.66	8.46	7.087	7.48	4.07	0.16	9.84	0.71	0.59	2.50	4	15.08	1.38
AC115	56C	9.06	8.46	7.087	6.10	4.53	0.16	9.84	0.71	0.59	2.17	4	14.71	1.38
AD3, AD7	56C	10.83	10.43	9.055	9.06	5.33	0.20	11.81	0.87	0.59	3.75	8	16.73	1.18
AD135	56C	13.00	10.43	9.055	7.68	3.94	0.20	11.81	0.87	0.59	2.76	8	15.70	1.18
AD145	56C	13.00	10.43	9.055	7.68	4.72	0.20	11.81	0.87	0.59	3.54	8	16.48	1.18
BD7	56C/140TC	10.83	10.43	9.055	9.06	5.33	0.20	11.81	0.87	0.59	3.75	8	17.40	1.18
BE3, BE7	56C/140TC	14.17	13.78	11.811	11.81	5.94	0.31	15.75	0.98	0.75	4.37	8	20.08	1.57
BE165	56C/140TC	16.14	13.78	11.811	9.37	5.47	0.31	15.75	0.98	0.75	3.54	8	19.25	1.57
BE375	56C/140TC	16.93	13.78	11.811	13.19	4.92	0.31	15.75	0.98	0.75	3.54	8	19.25	1.57
CE7	180TC	14.17	13.78	11.811	11.81	5.94	0.31	15.75	0.98	0.75	4.37	8	21.30	1.57
CE375	180TC	16.93	13.78	11.811	13.19	4.92	0.31	15.75	0.98	0.75	3.54	8	19.25	1.57
CF3, CF7	56C/140TC	16.73	15.75	13.780	14.37	7.67	0.31	17.72	0.98	0.75	5.50	8	23.50	1.38
	180TC													
DF7	210TC	16.73	15.75	13.780	14.37	7.67	0.31	17.72	0.98	0.75	5.50	8	25.39	1.38

Reducer Frame Size	C-Face Motor	CF	CG	CH	CJ	D	E	F	F1	G	H	HO	P	R
AB3, AB7	56C	M8	5.04	4.24	4.252	4.527	5.71	4.72	0.59	0.63	0.47	N/A	5.91	12.67
AB105	56C	M8	5.04	4.24	4.252	3.937	5.91	3.54	0.59	0.47	0.43	N/A	5.91	12.03
AC3, AC7	56C	M10	6.38	4.96	5.354	5.512	7.09	5.91	0.79	0.87	0.59	N/A	7.48	14.59
AC115	56C	M10	6.38	4.96	5.354	4.724	7.48	4.53	0.79	0.59	0.55	N/A	7.48	14.23
AD3, AD7	56C	M10	8.27	6.18	7.165	6.496	8.86	7.09	0.98	1.02	0.75	7.28	9.25	16.23
AD135	56C	M10	8.27	6.18	7.165	5.905	11.42	5.71	0.98	0.87	0.71	7.28	9.25	15.22
AD145	56C	M10	8.27	6.18	7.165	5.905	11.42	5.71	0.98	0.87	0.71	7.28	9.25	16.00
BD7	56C/140TC	M10	8.27	6.18	7.165	6.496	8.86	7.09	0.98	1.02	0.75	7.28	9.25	16.90
BE3, BE7	56C/140TC	M12	10.43	7.91	9.055	7.283	11.81	9.84	0.98	1.18	0.87	9.06	11.81	19.57
BE165	56C/140TC	M12	10.43	7.91	9.055	6.299	14.56	5.91	1.73	0.98	0.71	9.06	11.81	18.24
BE375	56C/140TC	M12	10.43	7.91	9.055	7.874	14.96	10.83	1.18	1.18	0.87	9.06	11.81	18.24
CE7	180TC	M12	10.43	7.91	9.055	7.283	11.81	9.84	0.98	1.18	0.87	9.06	11.81	20.91
CE375	180TC	M12	10.43	7.91	9.055	7.874	14.96	10.83	1.18	1.18	0.87	9.06	11.81	20.12
CF3, CF7	56C/140TC	M12	12.80	9.09	11.417	8.268	13.78	11.61	1.38	1.38	0.98	10.24	14.17	22.55
	180TC													23.14
DF7	210TC	M12	12.80	9.09	11.417	8.268	13.78	11.61	1.38	1.38	0.98	10.24	14.17	25.97

Reducer Frame Size	C-Face Motor	S	W	Output Shaft					Input Shaft			Net Weight (lbs.)	
				U	V	Key	T	L	UA	VA	Key	w/C-Face	w/o C-Face
AB3, AB7	56C	4.99	7.48	1.375	2.00	.313x.313x1.77	N/A	N/A	0.750	1.19	.188x.188x.98	53	46
AB105	56C	4.37	6.89	1.125	1.38	.250x.250x1.18	N/A	N/A	0.750	1.19	.188x.188x.98	54	52
AC3, AC7	56C	6.20	10.38	1.750	2.50	.375x.375x2.16	N/A	N/A	0.750	1.19	.188x.188x.98	91	84
AC115	56C	5.87	8.46	1.500	2.17	.375x.375x1.77	N/A	N/A	0.750	1.19	.188x.188x.98	96	85
AD3, AD7	56C	6.67	12.68	2.500	3.75	.625x.625x2.95	N/A	N/A	0.750	1.19	.188x.188x.98	150	145
AD135	56C	6.46	12.17	1.875	2.76	.500x.500x2.17	3/8-16UNC	0.71	0.750	1.19	.188x.188x.98	143	141
AD145	56C	7.24	12.17	1.875	3.54	.500x.500x2.95	3/8-16UNC	0.71	0.750	1.19	.188x.188x.98	143	141
BD7	56C/140TC	6.67	12.68	2.500	3.75	.625x.625x2.95	N/A	N/A	0.750	1.19	.188x.188x.98	161	150
BE3, BE7	56C/140TC	8.03	15.71	2.875	4.37	.750x.750x3.74	3/4-10UNC	1.38	0.750	1.19	.188x.188x.98	274	271
BE165	56C/140TC	7.20	14.73	2.250	3.54	.500x.500x2.95	3/8-16UNC	0.71	0.750	1.19	.188x.188x.98	271	269
BE375	56C/140TC	7.20	16.30	2.750	3.54	.625x.625x2.95	1/2-13UNC	0.94	0.750	1.19	.188x.188x.98	305	303
CE7	180TC	8.03	15.71	2.875	4.37	.750x.750x3.74	3/4-10UNC	1.38	1.000	1.56	.250x.250x1.25	304	293
CE375	180TC	7.20	16.30	2.750	3.54	.625x.625x2.95	1/2-13UNC	0.94	1.000	1.56	.250x.250x1.25	331	325
CF3, CF7	56C/140TC	9.09	17.89	3.625	5.50	.875x.875x4.53	3/4-10UNC	1.38	1.000	1.56	.250x.250x1.25	481	480
	180TC											489	
DF7	210TC	9.09	17.89	3.625	5.50	.875x.875x4.53	3/4-10UNC	1.38	1.125	1.75	.250x.250x1.37	528	520

Notes:
 All dimensions are in inches.
 To download CAD drawings, visit our website: www.shimpodrives.com.
 Size AB3 & AB7 do not include a lifting eye.

N/A - denotes dimension not applicable.
 See page 26 for C-Face dimensions.
 Dimensions subject to change without notice.

Dimensions Shovel Base & Top Mount Adaptor

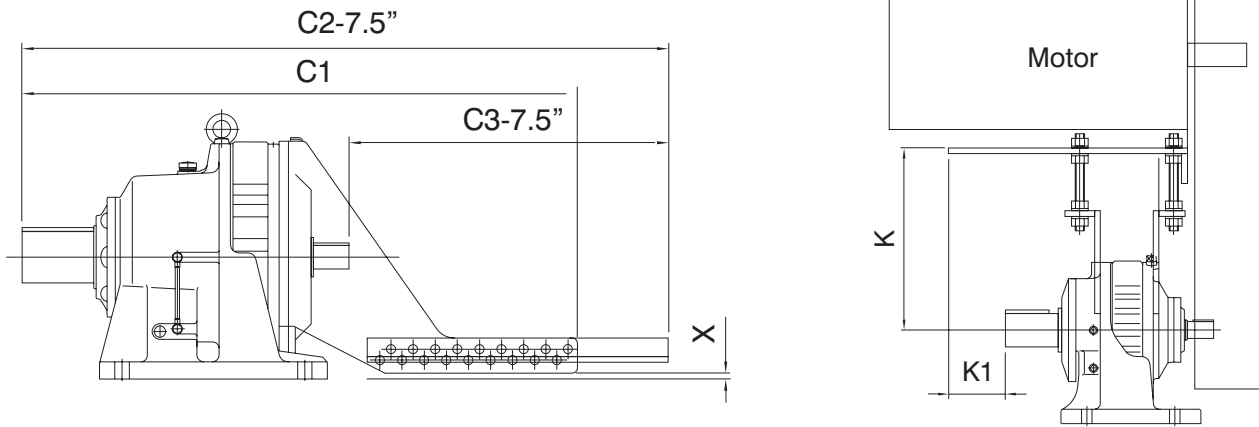

Reducer Frame Size	Shovel Base						Top Mount				
	Motor Frame Size	C1	C2	C3	X	Net Weight (lb)	Motor Frame Size	K		K1	Net Weight (lb)
								Min	Max		
C01 - C07	56-184T	31.10	34.35	21.63	0.76	93	56-184T	7.90	10.90	4.84	87
D01 - D07	143T-215T	32.04	38.29	24.12	0.95	162	145T-256T	9.20	12.20	3.59	140
E01 - E07	182T-256T	35.94	42.18	22.69	0.65	290	182T-256T	11.40	14.40	0.92	288
F03 - F07	213T-286T	37.27	47.24	24.29	2.40	590	213T-326T	15.10	18.10	-0.98	562

Notes:

All dimensions are in inches.

For Top Mount, total V-drive drive centers = "K" dimension listed PLUS motor "D" dimension.

Top Mount can be rotated. Contact SHIMPO Drives Customer Service for additional information. Dimensions subject to change without notice.

Dimensions C-Face Adaptor

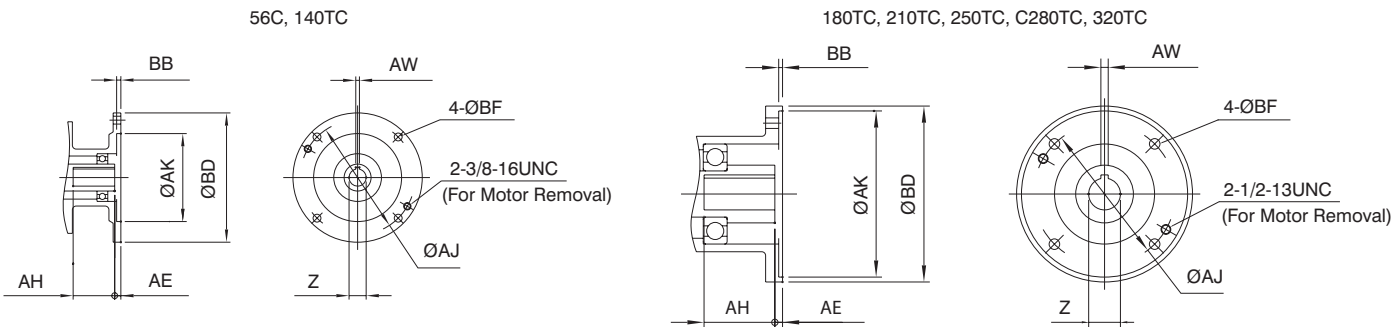

C-Face Motor Size	AE	AH	AJ	AK	AW	BB	BD	BF	Z
56C	0.31	1.92	5.875	4.50	0.188	0.217	6.61	0.40	0.625
140TC	0.39	2.13	5.875	4.50	0.188	0.217	6.61	0.40	0.875
180TC	0.39	2.60	7.250	8.50	0.250	0.217	9.00	0.54	1.125
210TC	0.39	3.15	7.250	8.50	0.313	0.197	9.00	0.54	1.375
250TC	0.39	3.62	7.250	8.50	0.375	0.217	9.00	0.54	1.625
280TC	0.47	4.33	9.000	10.50	0.500	0.217	11.14	0.54	1.875
320TC	0.35	5.24	11.000	12.50	0.500	0.217	13.39	0.71	2.215

Notes:

All dimensions are in inches.

Dimensions subject to change without notice.

Reducers for Overhead Conveyor Applications

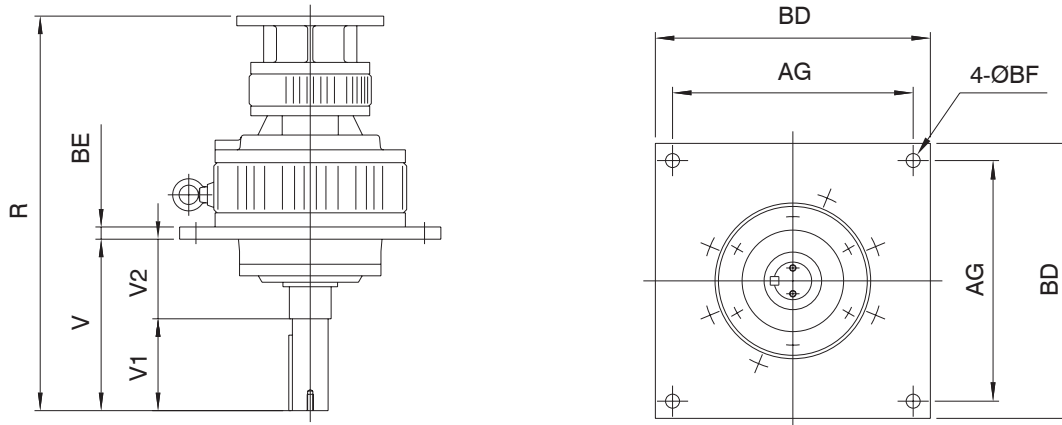

Matches industry standard mounting and output shaft dimensions

- Grease lubrication won't ever leak oil with minimal maintenance. Optional USDA approved grease available
- Straddle mount output shaft bearings maximize overhung load capability
- Quill style NEMA C-Face easily accommodates standard motors while minimizing overall length
- Motor back-off holes allow simple motor removal

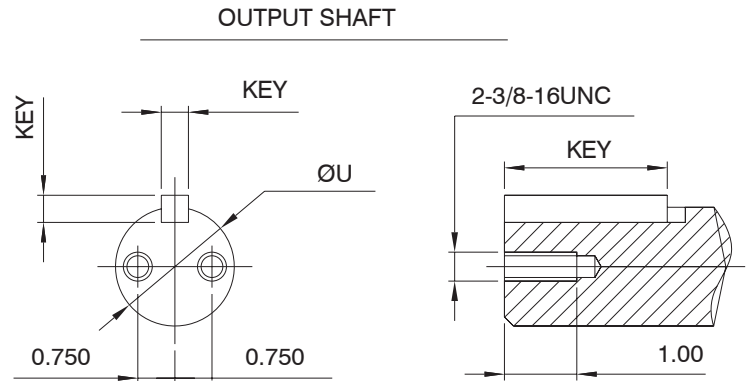

Reducer Frame Size	C-Face Motor Size	AG	BD	BE	BF	R	Output Shaft					Net Weight (lb)
							U	V	V1	V2	Key	
AD7-50	56C	14.00	16.00	0.625	0.81	19.03	2.1875	10.500	5.625	4.875	.500x.500x4.625	150
BD7-50	56C/140TC					19.72						161
BE3-50	56C/140TC					22.28						287
BE7-50	56C/140TC					22.28						287
	180TC	22.87	298									
BE7-60	56C/140TC	17.00	19.50	0.750	0.88	27.28	2.4375	15.500	7.625	7.875	.625x.625x6.50	329
	180TC					27.87						338
CE7-60	180TC					29.16						360

Notes:

All dimensions are in inches.
 To download CAD drawings, please visit our website: www.shimpodrives.com.
 See page 28 for C-Face dimensions.

See pages 12 & 13 for input HP and output torque ratings.
 Dimensions subject to change without notice.

Miscellaneous Engineering Information

Ambient Temperature

The ambient operating temperature range of the **CIRCULUTE 3000** Reducer is from 32°F to 104°F (0°C to 40°C). Contact SHIMPO Drives Customer Service if operating conditions fall outside of this range.

Backlash

The standard backlash option is approximately 1° (60 arc-min).

The precision backlash option is less than 0.1° (6 arc-min).

Direction of Rotation

The input shaft can be rotated in either direction. For single reduction reducers, the output shaft rotates in the opposite direction of the input shaft. For double reduction reducers, the output shaft rotates in the same direction as the input shaft.

Exact Ratio

All **CIRCULUTE 3000** reduction ratios listed in this catalog are exact.

Thermal Ratings

The high efficiency of the **CIRCULUTE 3000** Reducer results in thermal ratings which exceed its mechanical rating in all cases. Therefore, it can be run continuously at any of the input speeds in this catalog.

Table 1 Input Shaft Thrust & Overhung Load Capacity (lbs)

Reducer Frame Size	Load Type	Input Shaft Speed (rpm)			
		580	870	1165	1750
A	OHL	260	260	230	200
	Thrust	130	130	115	100
B	OHL	260	260	230	200
	Thrust	130	130	115	100
C	OHL	400	390	350	310
	Thrust	200	195	175	155
D	OHL	600	600	540	480
	Thrust	300	300	270	240
E	OHL	1,300	1,100	1,000	880
	Thrust	650	550	500	440
F	OHL	1,700	1,500	1,300	1,200
	Thrust	850	750	650	600

Notes:

Overhung load ratings are based on the load being applied to the center of the shaft.

Ratings shown are based on a combined overhung and thrust load being applied to the shaft.

Miscellaneous Engineering Information

Output Shaft Overhung Load

When a sprocket, sheave, pulley, or gear is mounted on the output shaft or on the input shaft, an overhung load is applied to the shaft. It is necessary to check whether the shafts of the reducer will allow the required overhung load.

Overhung Load Calculation

Calculate the overhung load using the formula below:

$$\text{Overhung Load} = \frac{126,000 \times \text{HP} \times \text{Cf} \times \text{Sf}}{\text{D} \times \text{N}} \times \frac{\text{K2} + \text{X}}{\text{K1}}$$

HP: Horsepower transmitted by the shaft

Cf: Load connection factor (from Table 2)

Sf: Service factor (from Service Factor Table on page 6 or 7)

D: Pitch diameter of sprocket, etc.

N: Shaft speed (rpm)

K1: Constant factor (from Table 3)

K2: Constant factor (from Table 3)

X: Distance from collar surface to load position (in)

Table 2 Load Connection Factor: Cf

Type of Connection	Factor
General Purpose Chain	1.00
Machined Gear, Pinion, or Synchronous Belt	1.25
V-Belt	1.50
Flat Belt	2.50

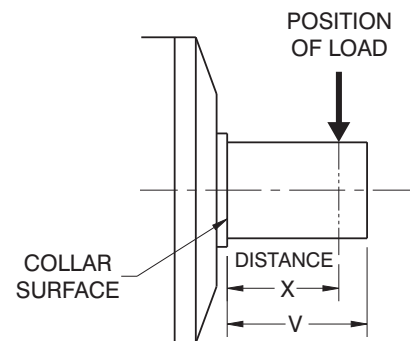

Table 3 Output Shaft Overhung Load Capacity (lb)

Reducer Frame Size	Output Shaft Speed (rpm)									Constant Factor	
	40 & Below	50	60	80	100	125	150	200	250 & Above	K1	K2
A	780	780	780	780	780	764	715	650	---	5.37	4.67
B AB	1,280	1,280	1,280	1,280	1,280	1,270	1,190	1,070	934	5.67	4.67
C AC	2,760	2,600	440	2,280	2,110	1,950	1,790	1,730	1,410	6.83	5.55
D AD, BD	5,040	4,710	4,550	4,060	3,740	3,580	3,250	3,090	2,690	8.26	6.38
E BE, CE	7,480	7,480	7,480	7,480	7,310	6,830	6,340	5,690	---	11.4	9.25
F CF, DF	12,200	12,200	11,500	10,600	9,750	9,100	8,610	7,800	---	13.9	11.1

Notes:

These ratings are based on thrust load = 0.

Contact SHIMPO Drives Customer Service for applications which have combined overhung & thrust loads.

Applications Examples

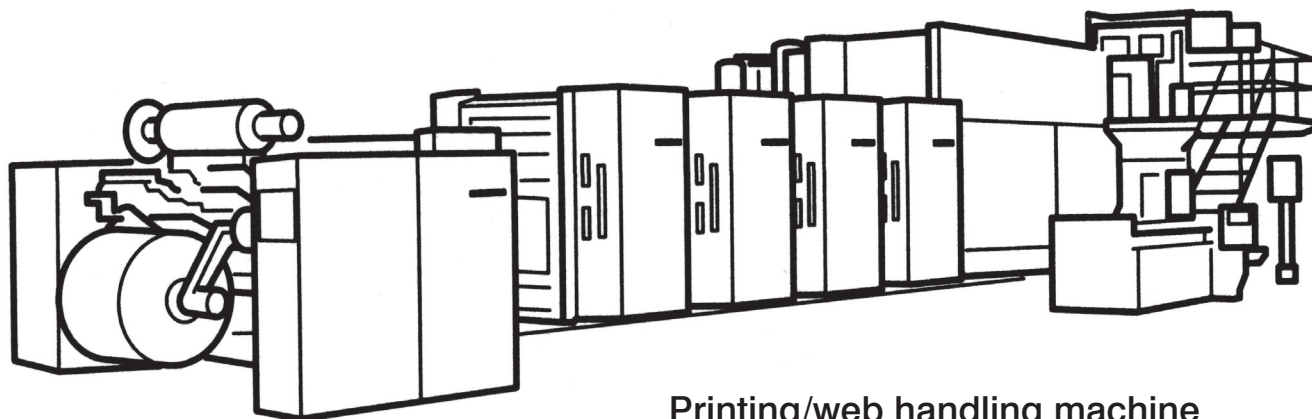

Printing/web handling machine

Parts loader/unloader

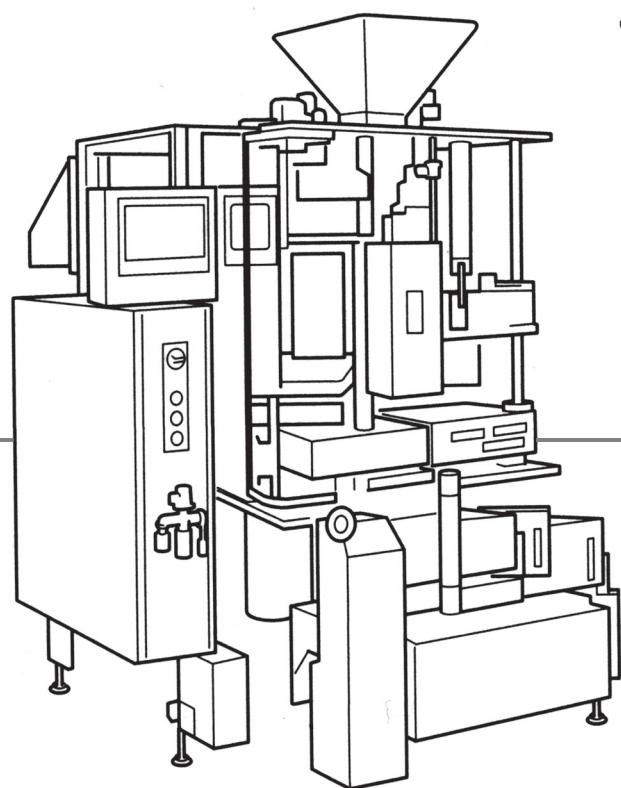
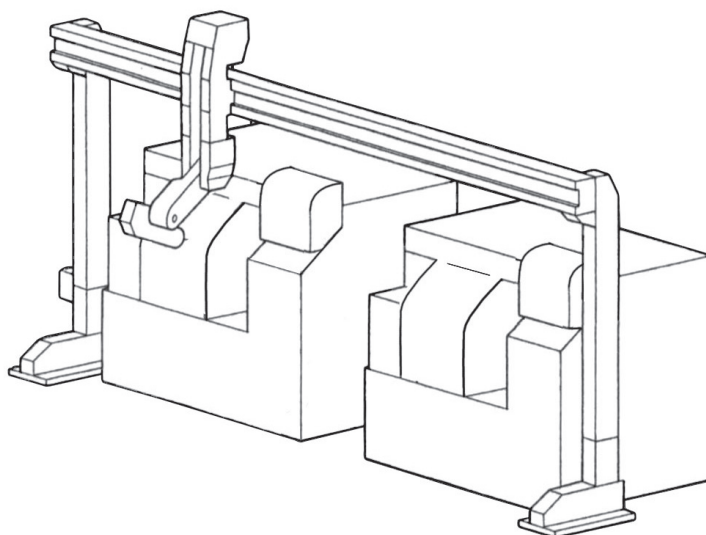

Vertical form, fill, & seal machine

Machining center tool changer

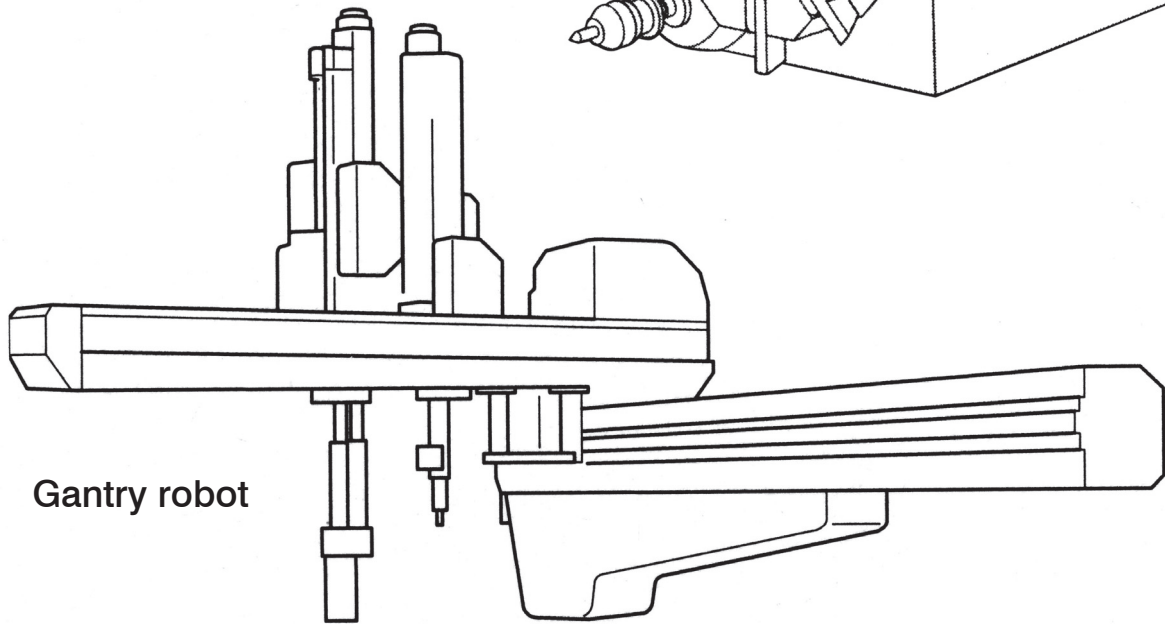
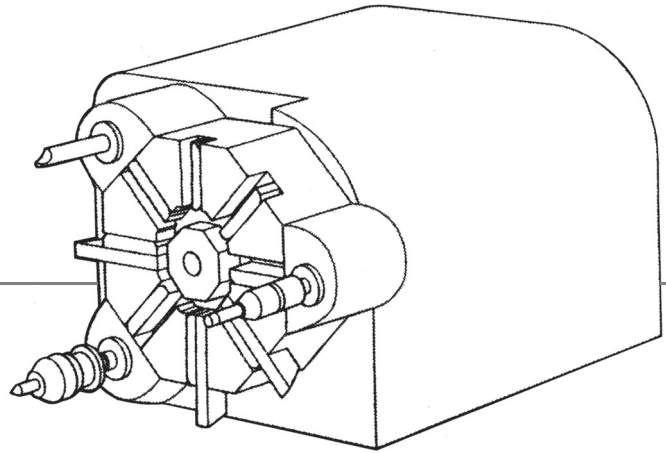

Gantry robot

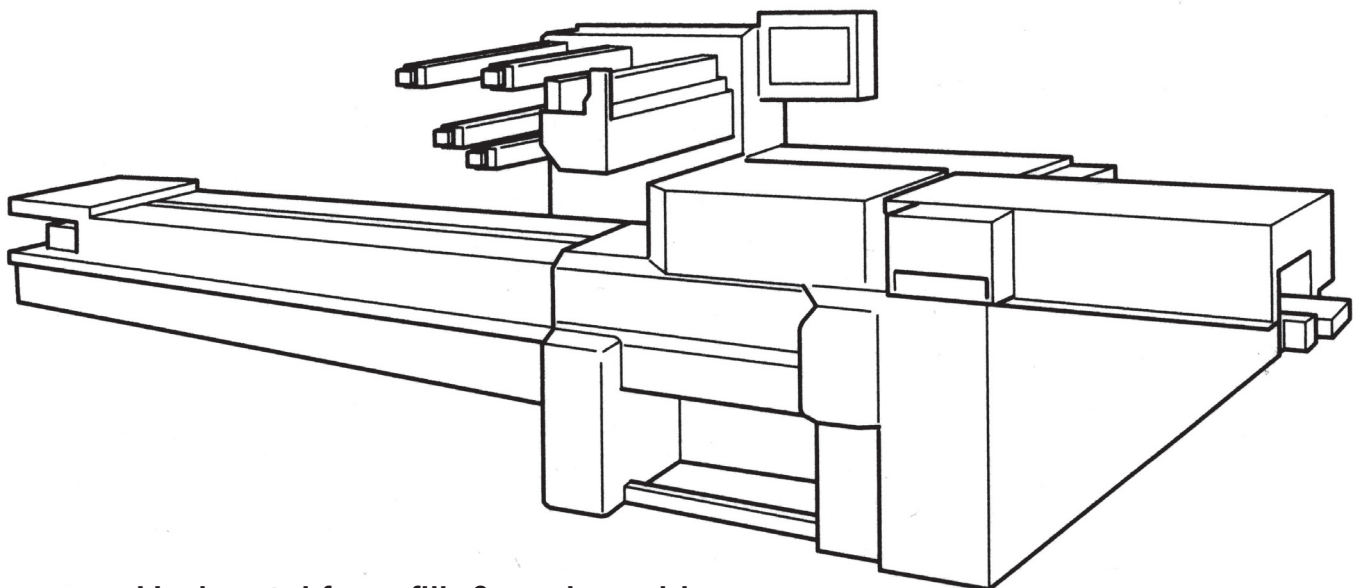

Horizontal form, fill, & seal machine

Introducing SHIMPO's Circulate Pulley

In addition to our standard assembly configurations, the **CIRCULATE 3000**® is also available with an integral pulley, with a hollow output shaft, or both. These configurations, available in three sizes, can be used in a number of situations to create a compact footless drive package.

For more information, see our brochure with full specifications and dimensions.

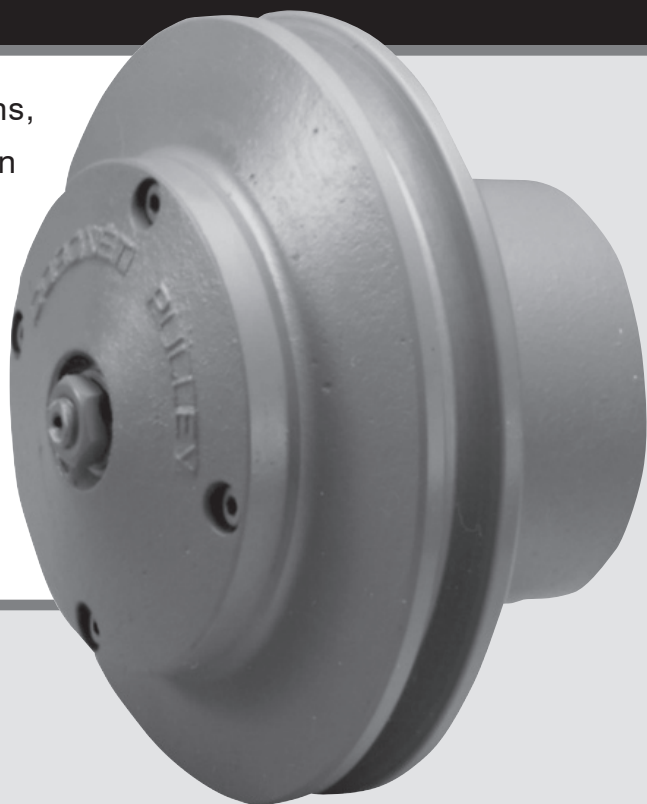

Available in the following configurations:

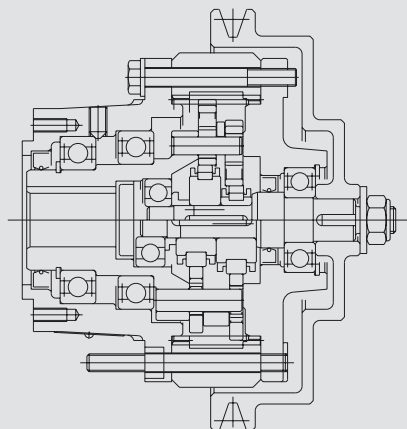

Circulate Pulley w/Hollow Shaft

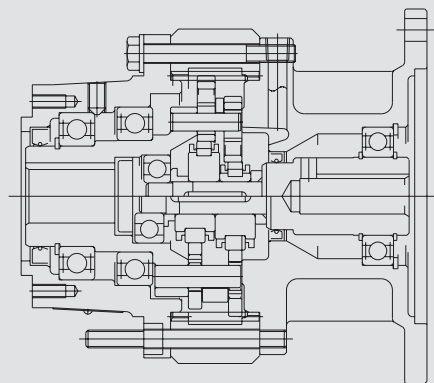

C-Face Input w/Hollow Shaft

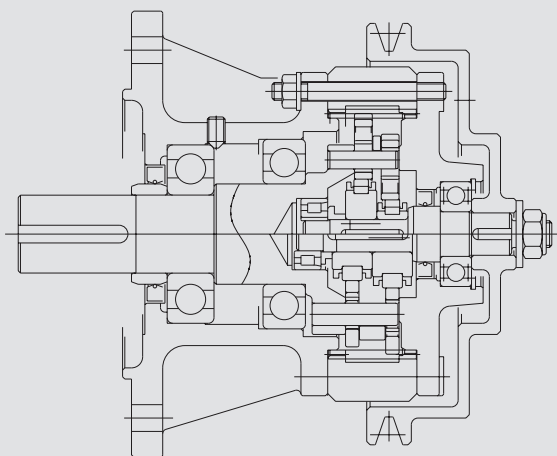

Circulate Pulley, Flange Mount

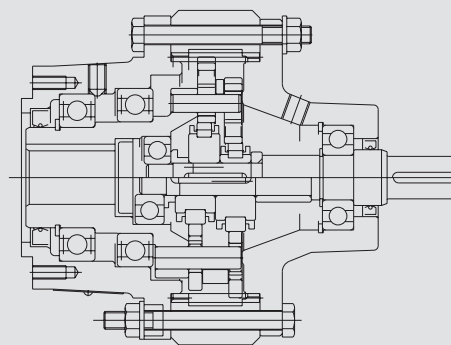

Shaft Input w/Hollow Shaft Output

SHIMPO Worldwide Facilities



1

Shimpo's North American headquarters is in suburban **Chicago** where we inventory, provide sales, engineering, and product support.

2

Shimpo's Regional offices are located in **California** and **North Carolina**, providing sales, engineering, and product support.



3

Shimpo's state-of-the-art factory and sales office in **China** combine to fill out a major presence throughout Asia.



4

Shimpo's corporate offices are in **Japan** where the company performs product research, development, and international sales support. ISO 9001 certified.

5

Shimpo's European presence is represented by a sales office in **Germany**.

The Complete Line of **Shimpo Drives** Products



Adjustable Speed Drive

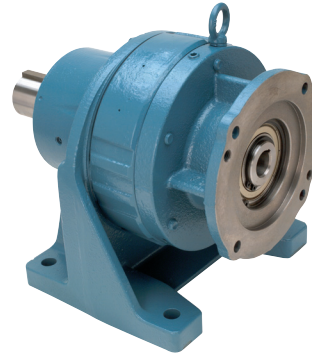

Speed Reducer



Servo Cycloidal Speed Reducer

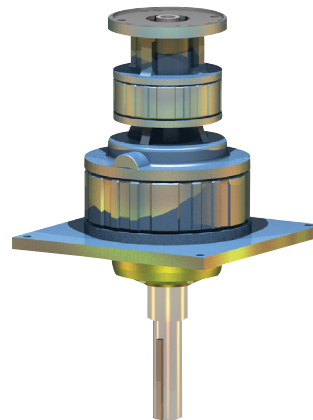

Overhead Conveyor Speed Reducer

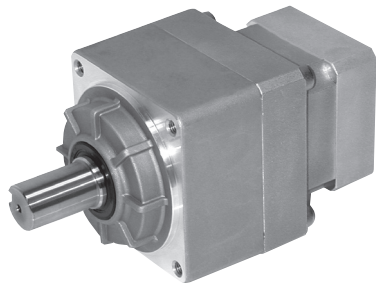

Servo Planetary Gearhead

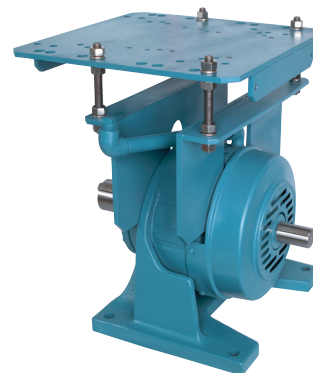

Top Mount Adaptor Reducer

DISTRIBUTED BY:

CIRC3000.002.0707

